

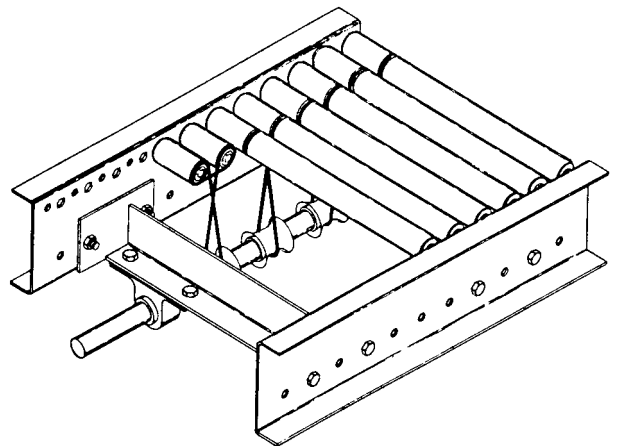

METZGAR
CONVEYORS

438,440 & 445 Series Lineshaft Driven Live Roller Conveyor Installation and Maintenance Manual

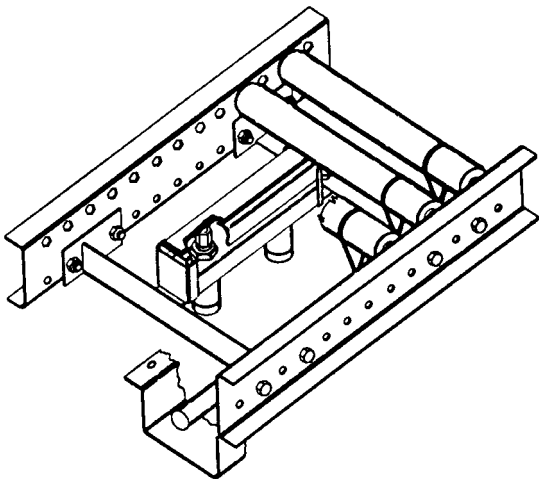

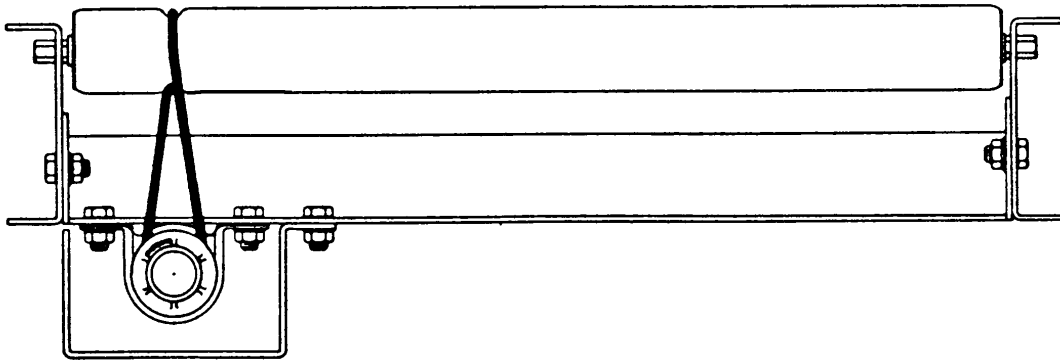

SAFETY PRECAUTIONS

WARNING: DO NOT ATTEMPT MAINTENANCE ON ANY CONVEYOR WHILE IT IS IN OPERATION.

BEFORE STARTING MAINTENANCE:

1. Maintenance functions are to be performed while the conveyor is off. The main power switch to the conveyor should be locked in the off position. This will prevent anyone from applying power to the system while maintenance personnel are at work.
2. Never work on a conveyor while it is running, unless maintenance procedure requires operation. When a conveyor must be operating to perform the maintenance; allow only properly trained maintenance personnel to work on the conveyor.

DURING MAINTENANCE:

1. Do not wear loose clothing while performing maintenance on operating equipment.
2. Be aware of hazardous conditions, such as sharp edges and protruding parts.
3. When using hoists, cables or other mechanical equipment to perform maintenance, use care to not damage conveyor components. Mis-aligned parts are dangerous as conveyor is started after maintenance is completed.
4. Keep area clean. Clean up lubricants and other materials before starting conveyor.

AFTER MAINTENANCE:

1. Before starting any conveyor after maintenance is completed, walk around the equipment and make certain all safety devices and guards are in place, pick up tools, maintenance equipment and clear any foreign objects from equipment-
2. Make certain all personnel are clear of the conveyor and made aware that the conveyor is about to be started.
3. Only authorized personnel should be permitted to start any conveyor following maintenance or emergency shut-off.

**PLEASE RECOGNIZE ALL WARNING STICKERS AND OBEY ANY SAFETY INSTRUCTIONS
WARNING STICKERS ARE PLACED FOR YOUR SAFETY – PLEASE DO NOT REMOVE**

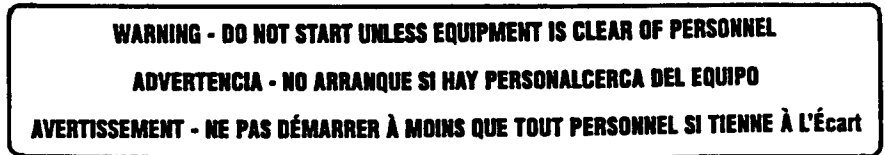
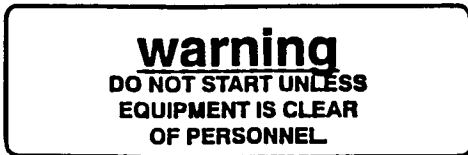

CONDITIONS DO EXIST ON ANY CONVEYOR THAT CAN CAUSE INJURY TO PERSONNEL. NO MANUAL CAN COVER ALL THE HAZARDOUS CONDITIONS THAT MIGHT DEVELOP. THEREFORE, PERSONNEL INVOLVED SHOULD BE CONSTANTLY ON THE ALERT FOR UNSAFE CONDITIONS AND USE ALL POSSIBLE CARE, ALONG WITH COMMON SENSE AND STRICT ADHERENCE TO ACCEPTED SAFETY STANDARDS TO ESCAPE INJURY.



Lineshaft Driven Live Roller Specifications:

438 Series Specifications

Rollers: 1-3/8" diameter x 18 gage galvanized tube with 5/16" hex axle with ball bearings.
 Roller ends are swaged over the bearings to provide a smooth, full length carrying surface.
 Roller grooves are cold formed in the roller shell.
 Roller axles are 5/16" hex stock spring loaded for easy removal and assembly.
 The top of the roller is 1/8" above the top flange of the frame.
 Standard roller centers are available in 1-1/2", 3" and 4-1/2"

Frame: 10 gage formed channel 4-1/2" deep with 1-1/4" flanges.
 Axle holes are 5/16" hex punched on 1-1/2" centers.
 Crossmembers are formed 10 gage steel bolted to frame.

Drive Belts: 1/8" diameter x 83A durometer.
 Drive Shaft: 1" diameter 1045 CRS to specific size tolerance.

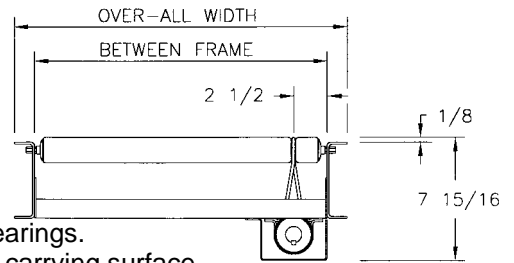

440 Series Specifications

Rollers: 1.9" diameter x 16 gage galvanized tube with 7/16" hex axle with ball bearings.
 Roller ends are swaged over the bearings to provide a smooth, full length carrying surface.
 Roller grooves are cold formed in the roller shell.
 Roller axles are 7/16" hex stock spring loaded for easy removal and assembly.
 The top of the roller is 5/16" above the top flange of the frame.
 Standard roller centers are available in 2-1/4", 3", 4-1/2" and 6"

Frame: 10 gage formed channel 4-1/2" deep with 1-1/4" flanges.
 Axle holes are 7/16" hex punched on 1-1/2" centers.
 Crossmembers are formed 10 gage steel bolted to frames.

Drive Belts: 3/16" diameter x 83A durometer.
 Drive Shaft: 1" diameter 1045 CRS to specific size tolerance.

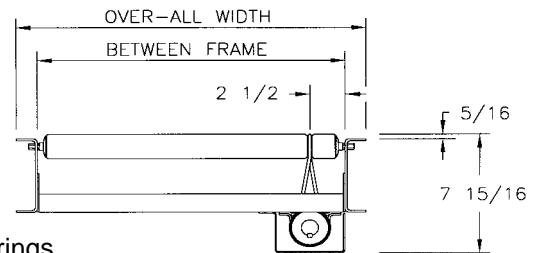

445 Series Specifications

Rollers: 2-1/2" diameter x 11 gage tube with 11/16" hex axle with ball bearings.
 Rollers have straight press bearings to provide a smooth, full length carrying surface.
 Roller grooves are cold formed in the roller shell.
 Roller axles are 11/16" hex stock spring loaded for easy removal and assembly.
 The top of the roller is 5/16" above the top flange of the frame.
 Standard roller centers are available in 3", 6" and 9"

Frame: 7 gage formed channel 9" deep with 1-1/2" flanges.
 Axle holes are 11/16" hex punched on 3" centers.
 Crossmembers are formed and welded 10 gage steel.

Drive Belts: 1/4" diameter x 83A durometer.
 Drive Shaft: 1-7/16" diameter 1045 CRS to specific size tolerance

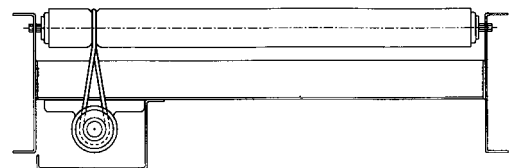

438/440 Series Lineshaft Drive:

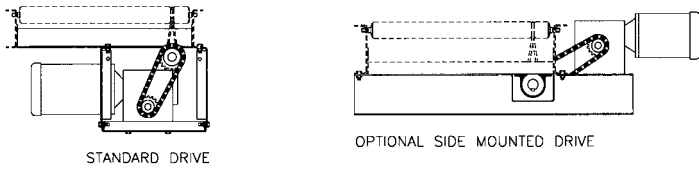

Lineshaft Transfer:

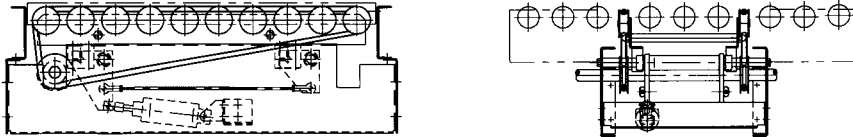

Lineshaft 90 Degree Curve:

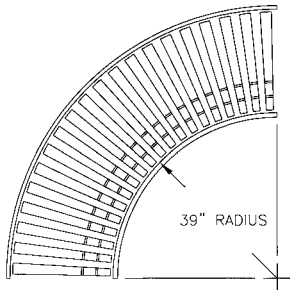

Lineshaft Air Brake:

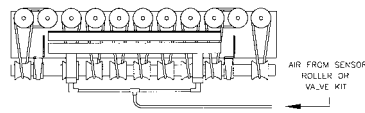

Pop-up stop:

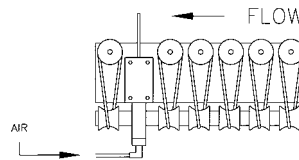

C700 Standard Support:

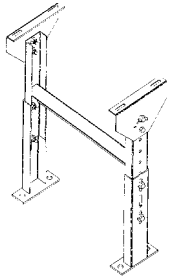

Hinged Gate:

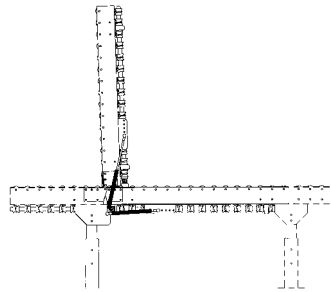

Lineshaft Merge Assembly:

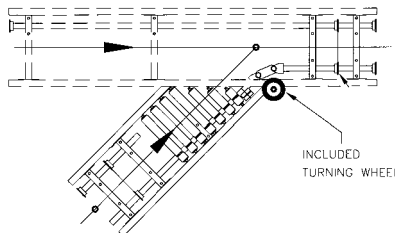

Lineshaft Divert Assembly:

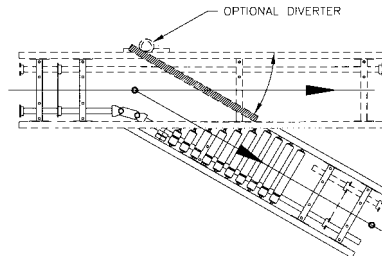

445 Series Lineshaft Drive:

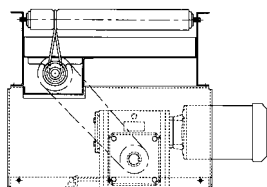



SUPPORT ASSEMBLY

Fasten supports to the bottom flange holes designed into each bed section.

Supports are installed directly under a bed joint to assist in the support of both bed sections. Install a support in the first available set of holes at both the charge end and the discharge end of the conveyor unit.

Mounting a support can be accomplished by either lifting the bed section into position onto a supporting member or attach the support directly to a bed section prior to lifting it into position.

Anchor supports after the conveyor has been aligned

Mounting diagonal braces at each end of a conveyor will increase stability. Heavy-duty applications or high elevations may require additional bracing located on closer centers.

Alignment of Lineshaft at Installation:

Conveyor frame sections need to be installed in a straight line. This can be accomplished over a long section of conveyor using a string on both ends. The Conveyor frames also need to have the same elevation. This is accomplished with the same string or with a long level. This will place the lineshafts from two adjacent sections close to being in alignment. Remove the bottom lineshaft guard and loosen the pillow block bearings holding the lineshaft to the crossmembers. Now is a good time to install the coupling chain. With the shafts aligned, retighten the pillow block bearings and replace the bottom lineshaft guard.

Installation of Coupling Chains at Bed Joints:

Remove the rollers at the conveyor bed joint for easy access to the coupling sprockets. Make sure the sprockets are aligned properly or the coupling chains will break. Rotate one of the shafts until the teeth on the sprocket are aligned. Loosen both the set screws on one of the sprockets so it can slide on the shaft. Install the coupling chain so the master link is on the top of the sprocket. Place the pin in the hole and gently tap the pin into the chain only if the sprockets are aligned. Tighten the set screws on the coupling sprocket and replace the rollers. Remove the coupling sprockets at locations where they are not required and install lineshaft end caps.

Switching Roller Direction of Flow:

The Direction the roller rotates can be reversed by removing the roller and changing the direction the drive belt is wrapped around the roller. Check the location of the positioning collar after the roller is reinstalled.

Location of Positioning Collars:

Positioning collars need to be positioned so the roller doesn't "walk" downstream on the shaft. If no positioning collar is present the drive belt will stretch causing a reduction in drive capacity. If unit is reversible positioning collars are required on both sides of the drive spool.

Transfer Adjustment:

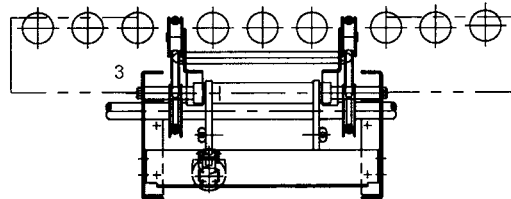
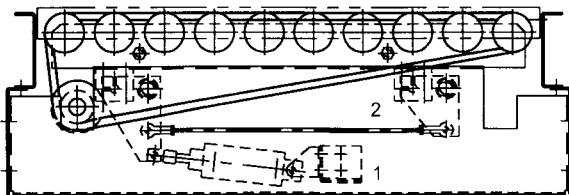

There are three adjustment locations on a lineshaft transfer for proper alignment.

The first is the cylinder mount bracket.

This will adjust the overall travel up and down of the transfer. If the transfer is level from side to side and front to back but is not raising the belts high enough or is raising the belts too high. Loosen the bolts on the side plate and move the cylinder mount either forward or back.

The second is the tie rods.

The tie rods should be set to equal lengths. The tie rods adjust the elevation of the transfer opposite the side with the cylinder.

The third is the bolts holding the pivot mechanism.

Two bolts on each side the transfer side plate have slots. Loosen the bolts and manually locate the pivot mechanism to be in level and in proper elevation with relation to the rollers. Repeat for the other side.



Skewing Rollers:

Moving the non drive side of a roller upstream or downstream one hex hole in the frame moves the product to the right or left side of the conveyor.

Air Piping Diagram for Standard Accumulation Circuit:

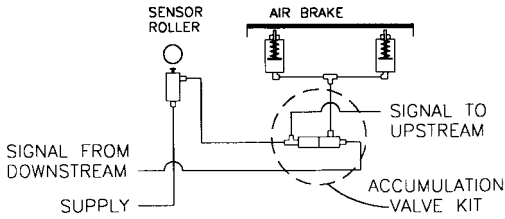

Drive Chain Tension And Alignment:

Chain Tension should be adjusted to allow 1/2" to 1" of movement between the sprockets.

Replace Chain Guard after adjusting chain tension.

Use a straightedge to align sprockets. Make sure the setscrews are tight when finished.

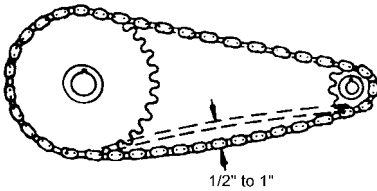



Mechanical Maintenance:

Item	Schedule	Service
Motors and Gear Reducer	At Start-up and 100 Hours	Check Oil
	After 100 Hours	Change Oil and Check Oil Level at Regular Intervals
	After 2000 Hours	Change Oil
Roller Chain	200 Hours	Check Tension at Regular Intervals
	2000 Hours	Clean and Lubricate with Brush or Spray
Pillow block Bearing(445 series)	2000 Hours	Lubricate
Sealed for Life Bearing Roller Bearings	Monthly	Check for Unusual Noise or Excessive Wear, Replace as Required

Note:

Gear Reduction Drives Supplied With Metzgar Belt Units Are Filled With Lubricant Prior To Shipping. The Lubricant Level Should Be Checked Prior To Start-Up and the Breather Plug Installed in the Proper Location (See Reducer Manual Supplied With Unit)
 Only Refill Reducers With The Approved Lubricant (Synthetic Compound)
 Standard Service Only - If Service Is More Severe, The Oil Should Be Changed More Frequently.
 Consult The Reducer Manufacturer For A More Specific Lubrication Schedule.

Electrical Maintenance:

WARNING: DISCONNECT ALL POWER BEFORE PERFORMING THE FOLLOWING MAINTENANCE. ONLY A QUALIFIED ELECTRICIAN OR AN ELECTRICAL TECHNICIAN SHOULD PERFORM THE FOLLOWING MAINTENANCE.

Item	Schedule	Service
Control Panels and Pushbutton Enclosures	Always	Enclosures should be Clean and Dry
	100 Hours and 2000 Hours	Check if components have Vibrated Loose Check Door/Power interlocks and Latches
	At Start-up, Monthly or if any problems Occur.	Check for Loose or Discolored Wires (Discolored Wires Indicate an Excessive Current Draw)
Photoeyes	At Start-up and 2000 Hours	Dust, Oil and Foreign Objects should be wiped from lens and Reflectors
Limit Switches	100 Hours and 2000 Hours	Check Arms for Adjustment and Tightness
Pushbuttons	100 Hours and 2000 Hours	Check Wires and Terminals for Tightness
Emergency Stop Devices	100 Hours and 2000 Hours	Check for Proper Operation
Conduit and Conduit Hangers	2000 Hours	Check for alignment and Damage, Exposed Wiring
Wiring	At Start-up, Monthly or if any problems Occur.	Check for Exposed Cords and Wires for Damage, Replace as Necessary

Note:

A Qualified Electrician Or Electrical Technician Should Keep A Log Book Of The Following Readings with any Excessive Deviation from Normal, Signals a Problem Area.

1. Measure Voltages And Current Of Incoming Power To Enclosure
2. Measure Current Readings Of All Motors
3. Measure Current Readings On Primary And Secondary Of Control Transformer To Insure Proper Infeed And Outfeed Voltage

Review Spare Parts:

Review Usage - Excessive Use of Fuses Or Replacing The Same Part Several Times Indicates an Excessive Current Draw, Faulty Components, or Exceeding The Capacity of the Conveyor Unit.



Trouble Shooting Guide:

Problem	Possible Cause	Remedy
Insufficient Drive	Not Enough rollers being driven	Drive More Rollers if Available
	Poor Uneven Bottom of Product	Change Surface in Contact with the Rollers
	Lubricant on Lineshaft	Clean Shaft with Degreaser
	Weakened Drive Belts	Replace Drive Belts
	Interference	Reduce Friction of Guard Rail or Remove Obstruction
Excessive Accumulation Pressure	Too Many Rollers Driven	Remove Drive Belts to Reduce Pressure
	Accumulating Excessive Distance	Break up Line Pressure with Brakes
	Belts Too Strong	Replace Belts with Less Drive Capacity
Rollers not turning or Turning Slowly	Weakened Drive Belts	Replace Drive Belts
	Worn Bearings in Roller	Replace Roller or Roller Bearings
	Interference With Roller or Drive Belt	Adjust for additional Clearance
	Roller is Bent	Replace Roller
Broken Drive Belt	Belt is Rubbing on an Obstruction	Remove Obstruction
	Product has Sharp Edge or Staples	Skew Rollers so product doesn't go over drive belt
Weakened Drive Belts	Reaction to Chemicals	Replace Belt and Remove Cause
	Excessive Elongation	Replace Belt and Reposition Spool and Collar
	Ultra-Violet Rays	Replace and Block from Sunlight
Belt out of Groove	Lineshaft is Miss located	Adjust Lineshaft to be Directly under Roller Groove
	Product Contacted Belt	Skew Rollers so product doesn't go over drive belt
Vibration in Lineshaft	Misalignment at Bearings	Loosen Bearings and Realign Shaft
	Misalignment at Couplings	Remove Coupling Chain and Align Shaft
	Bent or Worn Shaft	Replace Shaft
	Worn Sprockets or Chain	Replace Drive Components as Required
Vibration in Curve	Universal Joints out of Phase	Check for Keyway alignment, machine if required
Pulsation after Curve	Universal Joints out of Phase	Adjust Lineshafts
Rollers Pulsate	Speed too Slow	Minimum Speed for Lineshaft is 20 Feet Per Minute
Drive Chain Noise	Chain Loose	Tighten
	Misaligned Sprockets	Align Sprockets with Straight Edge
	Chain Rubbing on Obstruction	Move Obstruction or Adjust Chain and Sprockets
	Elongated, Worn or Broken Chain	Replace worn out Components
	Inadequate Lubrication	Lubricate
Reducer or Motor Noise	Insufficient Lubricant	Fill Reducer to Proper Level
	Worn Bearings or Gears	Replace Worn Components
Broken Coupling Chain	Improper Installation	Align Shafts and Replace Coupling Chain
	Lineshaft Misaligned	Align Shafts and Replace Coupling Chain
Brake wont hold Against Line Pressure	Pad not Contacting Roller	Shim Brake Assembly
	Low Air Pressure	Raise Air Pressure to 65 PSI
	Padded Channel Bent	Replace Channel
	Accumulation Distance too Great	Add Additional Brake zones to Reduce Pressure
	Light Product	Add Brakes or Coat Rollers to Increase Roller to Product Friction at Brake Zones.



Motor and Gear Reducer:

Hard To Start, Stalling Out Or Running Hot	Drag On Conveyor	Inspect For Obstruction Causing Drag And Remove
	Lack Of Lubricant	Check Oil Level In GearBox, Verify Vent Plug Is Open
	Frozen Bearing	Inspect All Bearings, Replace If Faulty
	Frozen Roller	Inspect All Rollers, Replace If Faulty
	Overloaded	Remove Load And Possibly Increase Horsepower
	Electrical	Check Wiring, Circuits And Take Amp Readings
Excessive Noise	Lack Of Lubricant	Check Oil Level In Reducer & Add If Needed
	Damaged Gears	Replace Unit
	Faulty Bearing	Replace Bearings

Chain and Sprockets:

Abnormal Wear	Excessive Chain Tension	Reduce the Chain Tension
	Mis-Aligned Sprockets	Align Sprocket Faces with Straight Edge
	Chain not Lubricated	Lubricate with Proper Lubricant
	Damaged Chain or Sprocket	Replace Damaged Component
	Mis-Aligned Chain Guard	Adjust as Required
Excessive Noise	Loose Chain	Adjust Chain Tension
	Chain not Lubricated	Lubricate with Proper Lubricant
	Mis-Aligned Sprockets	Align Sprocket Faces with Straight Edge
Pulsating Chain	Improper Chain Tension	Adjust Chain Tension
	Overload	Inspect for obstruction causing drag and remove
Broken Chain	Frozen Pulley, Sprocket or Shaft	Inspect and Replace Damaged Items
	Worn or Damaged Chain	Replace Damaged Chain
	Obstruction	Inspect Conveyor for Obstruction and Remove
Sprocket Loose on Shaft	Loose Set Screws	Align Sprocket Faces with Straight Edge and Tighten Set Screws
	Worn or Damaged Key	Replace Key and Inspect Shaft Keyway for Damage
Chain Slack	Normal Wear	Adjust Chain to Proper Tension

Electrical:

Motor Not Operating	Emergency Stop Activated	Reset Pull Cord, Air Pressure Switch or Pushbuttons
	Blown Fuses	If Resistance From Hot To Ground Is Ok Replace Fuse
	Overload Relay Tripped	Reset Relay, Measure Current Draw Amprobe
	Check For Wiring Problems	Check Wiring Diagram For Correct Connections
Belt Running Wrong Direction	3 Phase Motor – Switch 2 wires	Check Proper Voltage Wiring Diagram
	1 Phase Motor Wired Incorrectly	Check Proper Voltage Wiring Diagram
	DC Motor Wired Incorrectly	Check Proper Voltage Wiring Diagram
Overload Relay Trips	Check Setting On Overload Relay With Full Load Amps On Motor Nameplate	If Incorrect Reset Overload Relay To Motor Full Load Amps
	Check For Mechanical Binding Or Jams	Remove Item Creating Drag Load On Unit - Check Belt
	Additional Load Is Too Much For Motor	Decrease The Amount Of Product Load On Unit
	Check If Motor Current Draw Is High	Drive May Require More Horsepower-Consult Factory
Unit Operates Sporadically	Check Photoeyes	Clean Lens and Check for Proper Alignment
	Check Reflectors	Clean and Check for Proper Alignment
	Limit Switches	Check Arm Location and Tightness
	Solenoids	Check Pressure at the Valve
	Loose Connections	Check Wire Nuts and Terminal Strip

DO NOT ATTEMPT MAINTENANCE ON ANY CONVEYOR WHILE IT IS IN OPERATION



Lineshaft Replacement Parts:

438 Series Rollers:

Overall Width	1 3/8" Diameter Galvanized Single Groove	1 3/8" Diameter Galvanized Double Groove
12	438-12-RS-SG	438-12-RS-DG
15	438-15-RS-SG	438-15-RS-DG
18	438-18-RS-SG	438-18-RS-DG
21	438-21-RS-SG	438-21-RS-DG
24	438-24-RS-SG	438-24-RS-DG
27	438-27-RS-SG	438-27-RS-DG
30	438-30-RS-SG	438-30-RS-DG

438 Drive Belts:

438-DB-12	438 Drive Belt 1/8" x 12" long for 1 roller
438-DB-16.25	438 Drive Belt 1/8" x 16 1/4" long for pair of rollers
438-SB-8.25	438 Slave Belt 1/8" x 8 1/4" long for Slave between rollers on 3" Centers

440 Series Rollers:

Overall Width	1.9" Diameter Galvanized Single Groove	1.9" Diameter Galvanized Double Groove
12	440-12-RS-SG	440-12-RS-DG
15	440-15-RS-SG	440-15-RS-DG
18	440-18-RS-SG	440-18-RS-DG
21	440-21-RS-SG	440-21-RS-DG
24	440-24-RS-SG	440-24-RS-DG
27	440-27-RS-SG	440-27-RS-DG
30	440-30-RS-SG	440-30-RS-DG
33	440-33-RS-SG	440-33-RS-DG
36	440-36-RS-SG	440-36-RS-DG
39	440-39-RS-SG	440-39-RS-DG
42	440-42-RS-SG	440-42-RS-DG
45	440-45-RS-SG	440-45-RS-DG
48	440-48-RS-SG	440-48-RS-DG
51	440-51-RS-SG	440-51-RS-DG
54	440-54-RS-SG	440-54-RS-DG
57	440-57-RS-SG	440-57-RS-DG
60	440-60-RS-SG	440-60-RS-DG

440 Series Tapered Rollers:

Overall Width	1.9" Diameter Steel Double Groove
15	440-15-TRS-DG
18	440-18-TRS-DG
21	440-21-TRS-DG
24	440-24-TRS-DG
27	440-27-TRS-DG
30	440-30-TRS-DG
33	440-33-TRS-DG
36	440-36-TRS-DG
39	440-39-TRS-DG
42	440-42-TRS-DG
45	440-45-TRS-DG
48	440-48-TRS-DG

440 Drive Belts:

440-DB-13	440 Drive Belt 3/16" x 13" long for 1 roller
440-SB-9.75	440 Slave Belt 3/16" x 9 3/4" long for Slave between rollers on 3" Centers
440-SB-7.75	440 Slave Belt 3/16" x 7 3/4" long for Slave between rollers on 2 1/4" Centers
440-DB-11.78	440 Drive Belt Temporary Drive Belt 11 25/32" Long
440-DB-KIT	440 Drive Kit includes (30) Temp Fix Belts and (30) Split Spools



Parts 438/440

440-Spool	440 or 438 Drive Spool
440-Split Spool	440 or 438 Drive Screw Together Split Replacement Spool
440-FSpool	440 or 438 Fixed Drive Spool for positive drive
440-SpeedSpool	440 or 438 Speed-up Spool
440-Collar	440 or 438 Spool Collar (keeps spools in position)
440-XferSheave	440 Transfer Sheave for 7/16" diameter
440-BeltWKit	440 or 438 Belt Welding Kit
440-Bearing	440 or 438 1" ID Shaft Bearing
440-Shaft x length	440 or 438 1" Diameter Lineshaft (Specify Key Locations)
440-Coupling	440 or 438 Coupling Chain 8" long Delrin
440-SpktCoupling	440 or 438 Coupling Sprocket 40B16T x 1"
50B13T to 50B19	Standard Sprockets for #50 Chain
50-Chain	Feet of #50 Roller Chain
440-Ujoint	440 or 438 Universal Joint 1" Inside Diameter
440-GateCoupling	440 or 438 Spring Loaded Gate Coupling
440-StopBlock	440 pop-up Stop UHMW Block
440-CylStop	440 pop-up Stop Cylinder 1 1/2" bore x 2" stroke
440-CylAB	440 Air Brake Cylinder 1 1/4" bore x 1" stroke
440-CylXfer	440 Transfer Air Cylinder 1 1/2" bore x 2" stroke

445 Series Rollers:

Overall Width	2 1/2" Diameter Steel Single Groove
24	445-24-RS-SG
27	445-27-RS-SG
30	445-30-RS-SG
33	445-33-RS-SG
36	445-36-RS-SG
39	445-39-RS-SG
42	445-42-RS-SG
45	445-45-RS-SG
48	445-48-RS-SG
51	445-51-RS-SG
54	445-54-RS-SG
57	445-57-RS-SG
60	445-60-RS-SG

445 Drive Belts:

445-DB-16	445 Drive Belt 1/4" x 16" long for one roller
------------------	---

445 Parts:

445-Spool	445 Drive Spool
445-Shaft	445 Drive Shaft 1 7/16" Diameter
445-Collar	445 Positioning Collar
60B12T to 60B17T	Standard Sprockets for #60 Chain
60-Chain	Feet of #60 Roller Chain
445-Coupling	445 Coupling Chain #50 x 16 pitches Double Wide with Connector
445-SpktCoupling	445 Coupling Sprocket H50B-16Tx 1 7/16" Bore

Cord Stock for Transfers or Drive Belts

1/8"cord	Feet of 1/8" diameter cord stock
3/16"cord	Feet of 3/16" diameter cord stock
1/4"cord	Feet of 1/4" diameter cord stock
7/16"cord	Feet of 7/16" diameter cord stock
440-BeltWKit	Belt Welding Kit for 1/8", 3/16", 1/4" or 7/16" cord stock

Air Parts

440SR-Valve	440 Sensor Roller Valve
440ZP-Valve	Zero Pressure Accumulation Valve
1/4"Poly	Feet of 1/4" OD Polyflow Air Tubing
3/8"Poly	Feet of 3/8" OD Polyflow Air Tubing



Touch-Up Paint

MB-SPaint	Spray Can of Metzgar Blue Touch-up Paint
MB-1gCPaint	One Gallon Can of Metzgar Blue Touch-up Paint
VG-SPaint	Spray Can of Vista Green Touch-up Paint
VG-1gCPaint	One Gallon Can of Vista Green Touch-up Paint