

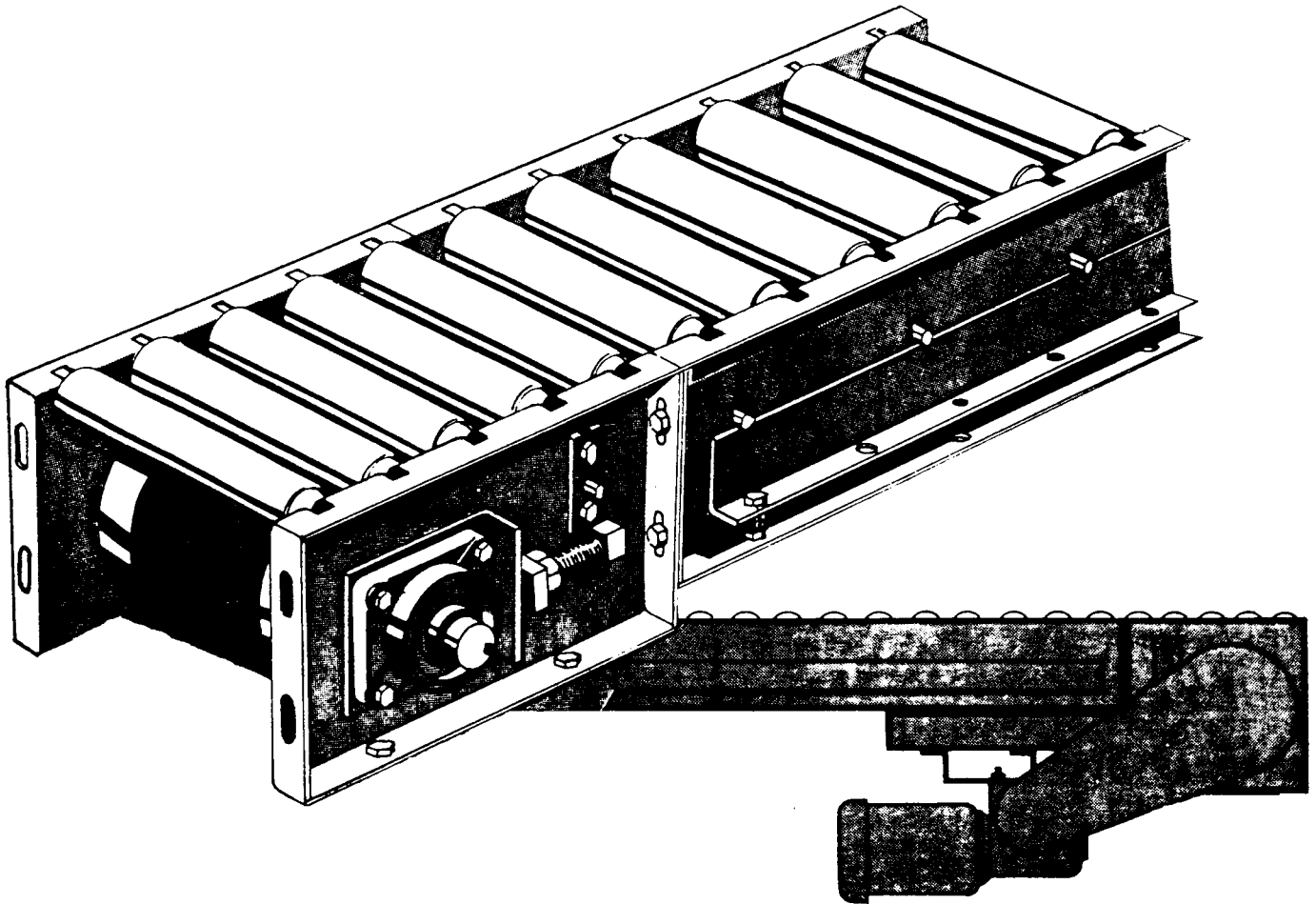

METZGAR
CONVEYORS

401, 430 & 460 Series Belt Driven Live Roller Conveyor Installation and Maintenance Manual





SAFETY PRECAUTIONS

WARNING: DO NOT ATTEMPT MAINTENANCE ON ANY CONVEYOR WHILE IT IS IN OPERATION.

BEFORE STARTING MAINTENANCE:

- 1. Maintenance functions are to be performed while the conveyor is off. The main power switch to the conveyor should be locked in the off position. This will prevent anyone from applying power to the system while maintenance personnel are at work.
- 2. Never work on a conveyor while it is running, unless maintenance procedure requires operation. When a conveyor must be operating to perform the maintenance; allow only properly trained maintenance personnel to work on the conveyor.

DURING MAINTENANCE:

- 1. Do not wear loose clothing while performing maintenance on operating equipment.
- 2. Be aware of hazardous conditions, such as sharp edges and protruding parts.
- 3. When using hoists, cables or other mechanical equipment to perform maintenance, use care to not damage conveyor components. Mis-aligned parts are dangerous as conveyor is started after maintenance is completed.
- 4. Keep area clean. Clean up lubricants and other materials before starting conveyor.

AFTER MAINTENANCE:

- 1. Before starting any conveyor after maintenance is completed, walk around the equipment and make certain all safety devices and guards are in place, pick up tools, maintenance equipment and clear any foreign objects from equipment-
- 2. Make certain all personnel are clear of the conveyor and made aware that the conveyor is about to be started.
- 3. Only authorized personnel should be permitted to start any conveyor following maintenance or emergency shut-off.

**PLEASE RECOGNIZE ALL WARNING STICKERS AND OBEY ANY SAFETY INSTRUCTIONS
WARNING STICKERS ARE PLACED FOR YOUR SAFETY – PLEASE DO NOT REMOVE**

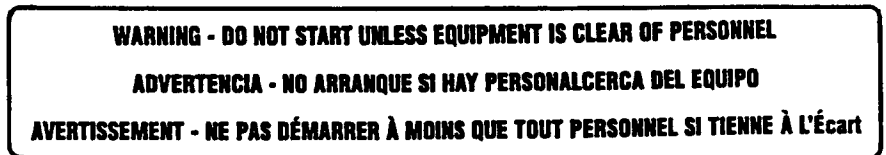

CONDITIONS DO EXIST ON ANY CONVEYOR THAT CAN CAUSE INJURY TO PERSONNEL. NO MANUAL CAN COVER ALL THE HAZARDOUS CONDITIONS THAT MIGHT DEVELOP. THEREFORE, PERSONNEL INVOLVED SHOULD BE CONSTANTLY ON THE ALERT FOR UNSAFE CONDITIONS AND USE ALL POSSIBLE CARE, ALONG WITH COMMON SENSE AND STRICT ADHERENCE TO ACCEPTED SAFETY STANDARDS TO ESCAPE INJURY.



UNPACKING INSTRUCTIONS:

Equipment must be removed carefully and safely from carriers.
Small loose items should be unloaded prior to large pallets.
Use shipping skids (not the equipment) to push pull or lift.
Always check and unload equipment against the BILL of LADING or packing slip to confirm a complete shipment.

If any equipment received damaged, always file claims with the shipping carrier.
Metzgar Conveyor Company does not file claims with the trucking carriers for damaged shipments.
Metzgar will invoice for any parts ordered to replace damaged items.
The cost of these items should be included in your claim to the carrier.
Store the equipment in a clean area prior to installation.
Leave work space around stored equipment to safely conduct an inventory of items.
Always reference the conveyor serial number located on the chain guard when requesting any replacement parts.

ELEVATION EXAMPLES:

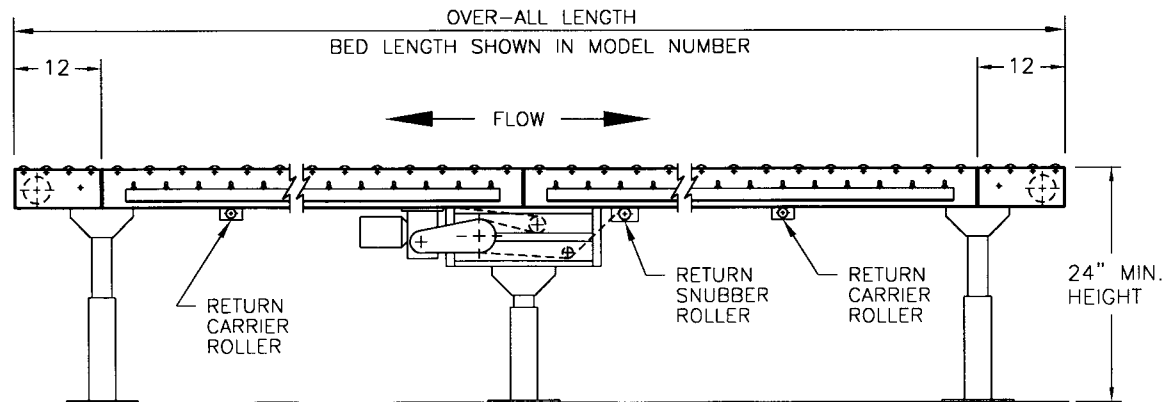
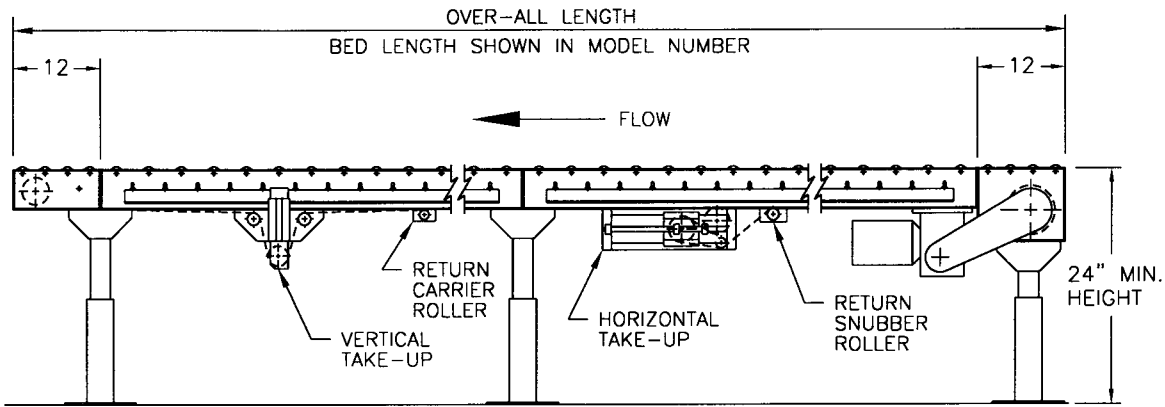



EQUIPMENT ASSEMBLIES:

The SERIES 401&430 conveyors ship in sub-assemblies due to size, weight and possibility of damage to components. Sub-assemblies are packaged for shipment using combinations of wood, corrugated cardboard and steel strapping.

END DRIVES: assembled, mounted to the bed complete with motor, sprockets, chain and guard

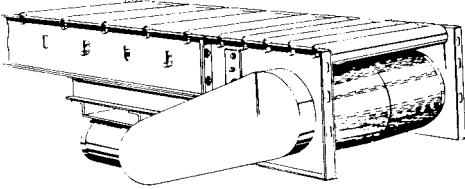

CENTER DRIVES: assembled, mounted to the bed complete with motor, sprockets, chain and guard

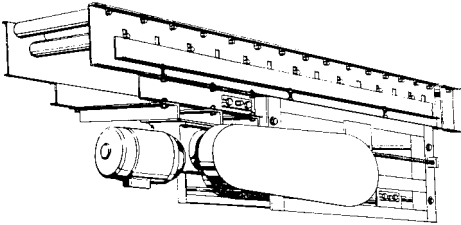

BED SECTIONS: complete with pressure rollers, and guard rail tubes.

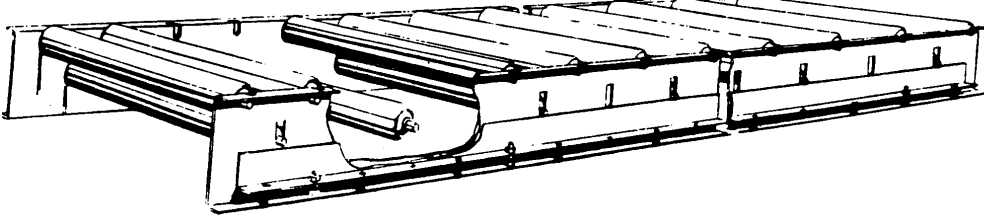

END PULLEY: assembled and ready to be mounted on the bed section at the end of conveyor.

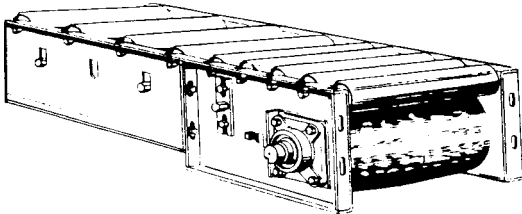

BELT: rolled with the lacing pin located in the lacing at one end.

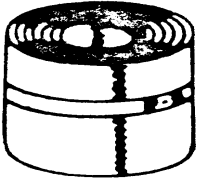

ROLLERS: Pressure Rollers shipped installed in the frame.

Carrier Rollers and Return Belt Rollers and Mounting Brackets are shipped in a separate container.



SUPPORTS: depending on the size and quantity, they may be separate or bundled.

DIAGONAL BRACES: shipped bundled in convenient quantities.

CHANNEL GUARD RAILS: bundled in convenient lengths with mounting rods bundled separately.



GENERAL INSTALLATION:

Series 401& 430 belt conveyor components can be installed in a variety of configurations. This manual is restricted to specific portions of the general installation where questions are most likely to arise.

Familiarize yourself with all the components that make up your conveyor or conveyor system, then organize the components to their proper position at the area where your equipment will be installed, always double check any building or obstacle dimensions that are critical to *your* installation area.

BED ASSEMBLY

When connecting beds together use the support or ceiling hanger support as the connection. Align the end of the second bed section to the end of the first bed section and bolt through the holes provided at the supports with the proper fasteners.

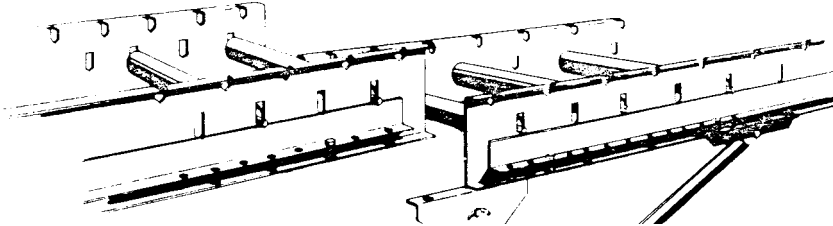

SERIES 401 and 430 belt driven live roller bed sections must be installed square. Check each section with a diagonal measurement to opposite corners, adjust as required for a like dimension. Installing a support, ceiling hanger or truss, as required.

SUPPORT ASSEMBLY

Fasten supports to the bottom flange holes designed into each bed section.

Supports are installed directly under a bed joint to assist in the support of both bed sections. Install a support in the first available set of holes at both the charge end and the discharge end of the conveyor unit.

Mounting a support can be accomplished by either lifting the bed section into position onto a supporting member or attach the support directly to a bed section prior to lifting it into position.

Anchor supports after the conveyor has been aligned and the belt has been tracked.

Mounting diagonal braces at each end of a conveyor will increase stability. Heavy-duty applications or high elevations may require additional bracing located on closer centers.

CEILING HANGERS

METZGAR CONVEYOR CO. offers cross pipes, fasteners and optional drop rods for ceiling hung installations.

Uprights and header steel is to be supplied by others.

Install ceiling hangers by mounting the cross pipes to the bed sections at floor level, then lifting one bed section into position and bolting the cross pipe to the uprights furnished by the installer. If installation is further than three feet from any support surface, secure bed joint with additional bracing- Splice plates are furnished for additional strength and alignment at every bed joint. This procedure should be repeated to complete the conveyor installation.

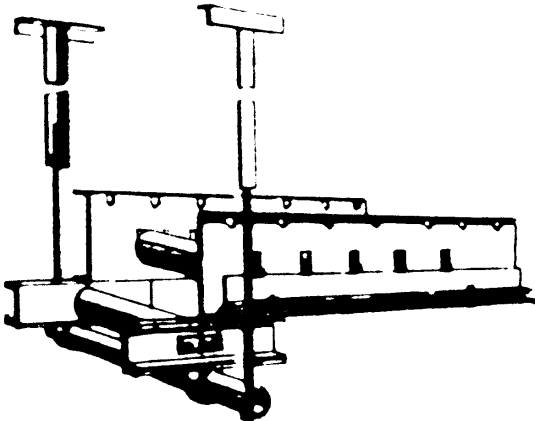



CHANNEL GUARDRAIL ASSEMBLY:

Adjustable channel guardrail can be mounted to bed sections after conveyor is properly installed into position. Insert the "L" shaped mount arms into the conveyor crossmember "guide tube" and hand tighten the adjustment screws under the conveyor. Fasten the two-piece mount bracket to the vertical arm upright and attach the guardrail channel to the opposite side. Locate the guardrail to the proper height and width for product movement and tighten all fasteners. If the guardrails on adjoining beds aren't matched correctly, the product may hang up creating a jam.

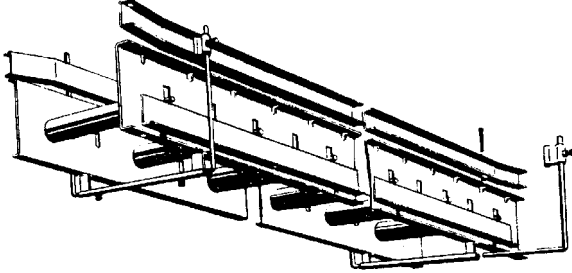

Chain Tension And Alignment:

Chain Tension should be adjusted to allow 1/2" to 1" of movement between the sprockets. Replace Chain Guard after adjusting chain tension. Use a straightedge to align sprockets. Make sure the setscrews are tight when finished.

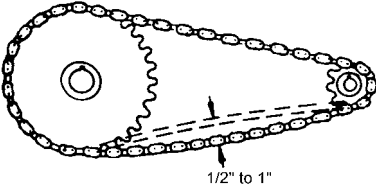

430 Series Accumulator Conveyor:

430 Series Belt Driven Live Roller Conveyor is shipped exactly the same as the 401 series. Carrier rollers and Belt Return Rollers are shipped in a separate container. Belt Pressure Rollers are shipped installed in the conveyor frame.

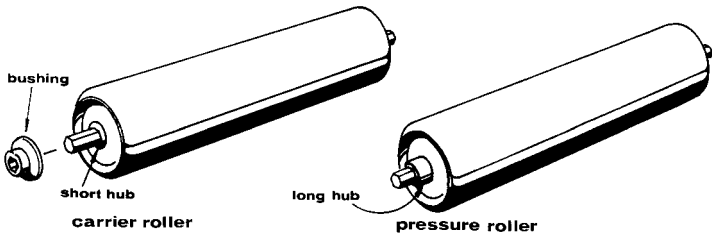

430 Series conveyor will accumulate in one direction only. The direction of flow must be as shown below. All roller adjustments should be made with the heaviest carton on the conveyor. Raise the pressure angles only high enough to move the carton.

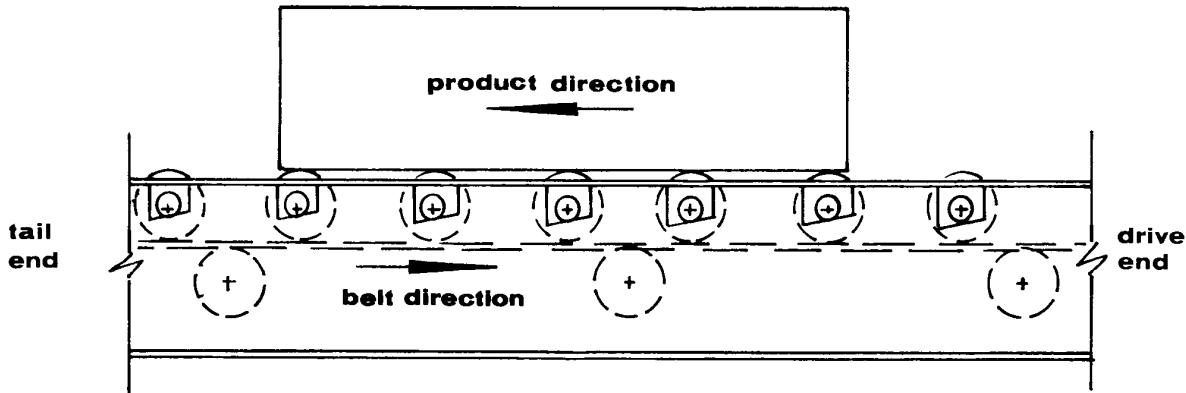



BELT INSTALLATION AND TRACKING:

Install the belt after all the conveyor bed sections have been squared. This should eliminate the possibility of a non-square bed making belt tracking difficult.

1. Adjust the take-up pulleys inward to allow for as much slack as possible when joining belt ends.
2. The belt is cut to length, laced and rolled with the carrying surface inside for shipping. Place the belt roll on the bed and unroll, the carrying surface should be facing upward.
3. Thread the belt through the drive pulley, snubber roller, carrier rollers and end pulleys as shown in the illustrations on page 3. Take care to insure the correct belt path and when possible, join ends as close to the unit end as possible, this will ease in the installation of the lacing pin.
4. After the belt is properly installed, take up the belt slack evenly with the end pulley assemblies or additional horizontal or vertical take-ups. Then install the belt carrying rollers.

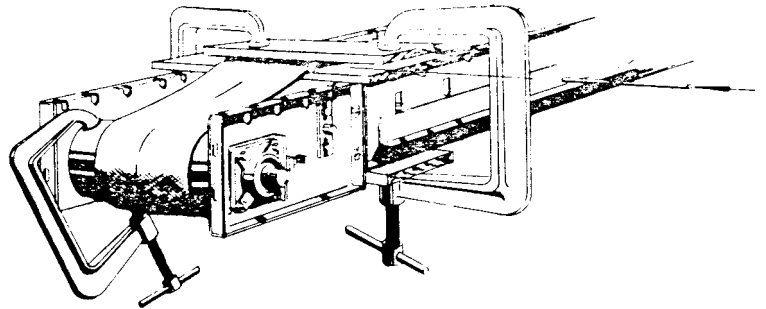
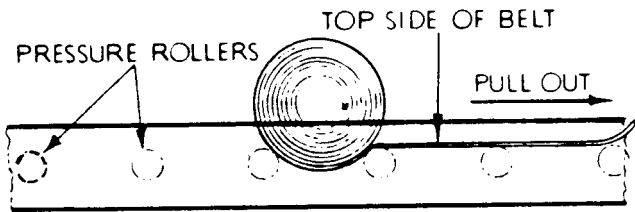

BELT TRACKING

Adjust all pulleys and rollers square with the bed. Tracking adjustments should be made in small increments and observed for a minimum of two belt rotations before further adjustments are made. If the belt moves slightly to one side of the pulley and returns during a revolution, the belt tracking is normal and should not require any additional adjustments.

When the belt tracks correctly and all the adjustments are finished be sure to tighten any locking means provided to maintain belt tracking.

Make sure conveyor has been installed level(from side to side)and that the conveyor is in a straight line.

Check all return roller brackets to make sure they are centered in their slots and that the drive pulley is centered.

Look at the belt, it should be tight enough so that you can only raise it up 2 inches in the middle.

Check the end pulleys to see that they are adjusted out evenly .

Turn the unit on and watch the belt run to see if it is tracking .

How to adjust belt tracking

1. The snubber that is closest to the end pulley at the load end will control most belt tracking. Loosen the bolts on the snubber bracket(right side) and slide away from feed end. Move to the right and towards infeed end to move the belt to the left.
2. Watch the belt for a couple of revolutions to see if the belt is moving the right direction.
3. It may be necessary to adjust some of the other return rollers the same way.
4. If the belt still wants to go to one side, you can adjust the end pulley out on the side the belt is trying to go towards. If possible It is best to track the belt using the return rollers rather than the end pulley.
5. Center drive take up pulleys have great affect on the belt tracking. Track these the same way as the end pulleys.

Return Roller

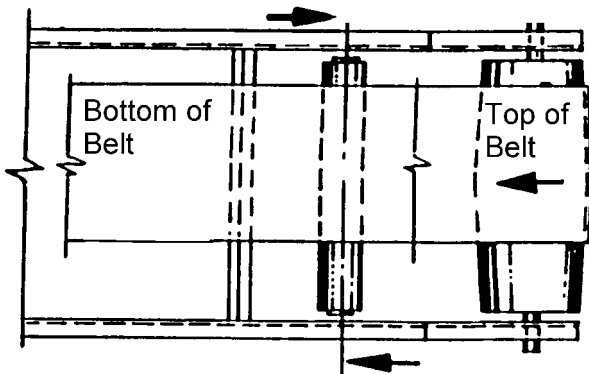



Mechanical Maintenance:

Item	Schedule	Service
Motors and Gear Reducer	At Start-up and 100 Hours	Check Oil
	After 100 Hours	Change Oil and Check Oil Level at Regular Intervals
	After 2000 Hours	Change Oil
Roller Chain	200 Hours	Check Tension at Regular Intervals
	2000 Hours	Clean and Lubricate with Brush or Spray
Flange Bearing	2000 Hours	Lubricate
Sealed for Life Bearing (End Take-up pulleys, Snubber and Return Rollers)	Monthly	Check for Unusual Noise or Excessive Wear, Replace as Required
Belt	Weekly	Check for Alignment and Tracking Re-track Belt as Required

Note:

Gear Reduction Drives Supplied With Metzgar Belt Units Are Filled With Lubricant Prior To Shipping. The Lubricant Level Should Be Checked Prior To Start-Up and the Breather Plug Installed in the Proper Location (See Reducer Manual Supplied With Unit)
 Only Refill Reducers With The Approved Lubricant (Synthetic Compound)
 Standard Service Only - If Service Is More Severe, The Oil Should Be Changed More Frequently.
 Consult The Reducer Manufacturer For A More Specific Lubrication Schedule.

Electrical Maintenance:

WARNING: DISCONNECT ALL POWER BEFORE PERFORMING THE FOLLOWING MAINTENANCE. ONLY A QUALIFIED ELECTRICIAN OR AN ELECTRICAL TECHNICIAN SHOULD PERFORM THE FOLLOWING MAINTENANCE.

Item	Schedule	Service
Control Panels and Pushbutton Enclosures	Always	Enclosures should be Clean and Dry
	100 Hours and 2000 Hours	Check if components have Vibrated Loose Check Door/Power interlocks and Latches
	At Start-up, Monthly or if any problems Occur.	Check for Loose or Discolored Wires (Discolored Wires Indicate an Excessive Current Draw)
Photoeyes	At Start-up and 2000 Hours	Dust, Oil and Foreign Objects should be wiped from lens and Reflectors
Limit Switches	100 Hours and 2000 Hours	Check Arms for Adjustment and Tightness
Pushbuttons	100 Hours and 2000 Hours	Check Wires and Terminals for Tightness
Emergency Stop Devices	100 Hours and 2000 Hours	Check for Proper Operation
Conduit and Conduit Hangers	2000 Hours	Check for alignment and Damage, Exposed Wiring
Wiring	At Start-up, Monthly or if any problems Occur.	Check for Exposed Cords and Wires for Damage, Replace as Necessary

Note:

A Qualified Electrician Or Electrical Technician Should Keep A Log Book Of The Following Readings with any Excessive Deviation from Normal, Signals a Problem Area.

1. Measure Voltages And Current Of Incoming Power To Enclosure
2. Measure Current Readings Of All Motors
3. Measure Current Readings On Primary And Secondary Of Control Transformer To Insure Proper Infeed And Outfeed Voltage

Review Spare Parts:

Review Usage - Excessive Use of Fuses Or Replacing The Same Part Several Times Indicates an Excessive Current Draw, Faulty Components, or Exceeding The Capacity of the Conveyor Unit.



Trouble Shooting Guide:

Belting :

Problem	Possible Cause	Remedy
Belt Slips On Drive Pulley	Take-Up Pulley Not Adjusted Properly	Adjust Each Take-Up Screw In Small Increments
	Face of Drive Pulley or Pulley Side of the Belt Is Slippery	Replace Lagging If Worn Smooth. If Objects In The Lagging Cause Slippage, Clean By Scraping With A Wire Brush. Do Not Use Belt Dressing, Thinners, Oils, Gasoline Or Solvents. These Items Could Impregnate a Belt or Pulley Lagging And Cause Pre-Mature Wear.
	Snubber Roller Is Misaligned	Realign Snubber To Increase Wrap on the Drive Pulley
Belt Lace Pulling Out	Belt Tension To Great	Reduce Belt Tension by Adjusting the Take-Up
Wear On Pulley Side of Belt	Belt Slipping On Drive Pulley	Adjust Each Take-Up Screw In Small Increments
	Pulley Or Roller Bearings Sticking	Check Alignment, Damage and Lubrication
	Misaligned Or Damaged Beds	Check Rollers For Smoothness and Alignment
Top Surface Of Belt Damaged	Obstruction	Inspect Conveyor For Obstructions And Remove
	Damaged Idler Or Snubber Roller	Check Return Idlers And Snubbers for Foreign Material
Belt Travels To One Side Of Unit	Rollers Upstream Not Square	Adjust Roller On Side Shifted, To Belt Travel Direction
	Bed Frame Structure Not Square	Check Bed With Level And Adjust To Proper Elevation
	Foreign Material On Roller Or Pulley Face	Clean Material Off Rollers And Pulleys And Check For Freeness And Alignment
	Belt Travels Off Drive Or Tail Pulley	Check Alignment Of Drive Pulley, Snubber Roller, Return Rollers Or The Slider Bed. Adjust Tail Pulley To Increase Tension On The Side Of The Belt Which Has Traveled "Don't Adjust Drive Pulley Except To Square It To Bed" The Snubber Roller Is Used To Track The Belt At The Drive Pulley

Pulleys:

Frozen or Stuck Pulley	Damaged Bearings	Replace Bearings with same Type
	Bent Shaft	Replace Shaft with Same Material, Diameter and Length
Pulley Travels or Slips on Shaft	Pulley Not Locked to Shaft	Tighten Set-Screws in Pulley Hubs
	Conveyor Not Installed Square	Square Conveyor Frames
	Conveyor Not Level	Adjust to Proper Elevation
	Belt Not Square to Center Line	Re-Cut Belt, Square Ends and Re-Lace
Noise	Lack of Lubrication	Lubricate Bearings
	Obstruction	Remove Obstruction
	Pulley Moved To One Side Of Unit	Center Pulley And Tighten Set Screws
Eccentric Pulley Or Wobble	Damaged Pulley Or Pulley Hub	Replace the Pulley
	Bent Shaft	Replace Shaft with Same Material, Diameter and Length
	Loose Bearings	Tighten or Replace Bearings
	Foreign Material On Pulley Face	Remove Foreign Material

Motor and Gear Reducer:

Hard To Start, Stalling Out Or Running Hot	Drag On Conveyor	Inspect For Obstruction Causing Drag And Remove
	Lack Of Lubricant	Check Oil Level In GearBox, Verify Vent Plug Is Open
	Frozen Pulley	Inspect All Pulleys And Bearings, Replace If Faulty
	Frozen Roller	Inspect All Rollers, Replace If Faulty
	Overloaded	Remove Load And Possibly Increase Horsepower
	Electrical	Check Wiring, Circuits And Take Amp Readings
Excessive Noise	Lack Of Lubricant	Check Oil Level In Reducer & Add If Needed
	Damaged Gears	Replace Unit
	Faulty Bearing	Replace Bearings



Chain and Sprockets:

Abnormal Wear	Excessive Chain Tension	Reduce the Chain Tension
	Mis-Aligned Sprockets	Align Sprocket Faces with Straight Edge
	Chain not Lubricated	Lubricate with Proper Lubricant
	Damaged Chain or Sprocket	Replace Damaged Component
	Mis-Aligned Chain Guard	Adjust as Required
Excessive Noise	Loose Chain	Adjust Chain Tension
	Chain not Lubricated	Lubricate with Proper Lubricant
	Mis-Aligned Sprockets	Align Sprocket Faces with Straight Edge
Pulsating Chain	Improper Chain Tension	Adjust Chain Tension
	Overload	Inspect for obstruction causing drag and remove
Broken Chain	Frozen Pulley, Sprocket or Shaft	Inspect and Replace Damaged Items
	Worn or Damaged Chain	Replace Damaged Chain
	Obstruction	Inspect Conveyor for Obstruction and Remove
Sprocket Loose on Shaft	Loose Set Screws	Align Sprocket Faces with Straight Edge and Tighten Set Screws
	Worn or Damaged Key	Replace Key and Inspect Shaft Keyway for Damage
Chain Slack	Normal Wear	Adjust Chain to Proper Tension

Electrical:

Motor Not Operating	Emergency Stop Activated	Reset Pull Cord, Air Pressure Switch or Pushbuttons
	Blown Fuses	If Resistance From Hot To Ground Is Ok Replace Fuse
	Overload Relay Tripped	Reset Relay, Measure Current Draw Amprobe
	Check For Wiring Problems	Check Wiring Diagram For Correct Connections
Belt Running Wrong Direction	3 Phase Motor – Switch 2 wires	Check Proper Voltage Wiring Diagram
	1 Phase Motor Wired Incorrectly	Check Proper Voltage Wiring Diagram
	DC Motor Wired Incorrectly	Check Proper Voltage Wiring Diagram
Overload Relay Trips	Check Setting On Overload Relay With Full Load Amps On Motor Nameplate	If Incorrect Reset Overload Relay To Motor Full Load Amps
	Check For Mechanical Binding Or Jams	Remove Item Creating Drag Load On Unit - Check Belt
	Additional Load Is Too Much For Motor	Decrease The Amount Of Product Load On Unit
	Check If Motor Current Draw Is High	Drive May Require More Horsepower-Consult Factory
Unit Operates Sporadically	Check Photoeyes	Clean Lens and Check for Proper Alignment
	Check Reflectors	Clean and Check for Proper Alignment
	Limit Switches	Check Arm Location and Tightness
	Solenoids	Check Pressure at the Valve
	Loose Connections	Check Wire Nuts and Terminal Strip

DO NOT ATTEMPT MAINTENANCE ON ANY CONVEYOR WHILE IT IS IN OPERATION



401, 430 & 460 BDLR Replacement Parts:

6" Drive Pulleys (5" Diameter plus Lagging) Includes 1 3/16" Diameter Shaft

Overall Width	Face Width	Pulley with 1 3/16" Bore
12"	7"	406-12Dpulley
15"	10"	406-15Dpulley
18"	13"	406-18Dpulley
24"	19"	406-24Dpulley
30"	25"	406-30Dpulley
36"	31"	406-36Dpulley
42"	37"	406-42Dpulley
48"	43"	406-48Dpulley

9" Drive Pulleys (8" Diameter plus Lagging) Includes 1 7/16" Diameter Shaft

Overall Width	Face Width	Pulley with 1 7/16" Bore
12"	7"	409-12Dpulley
15"	10"	409-18Dpulley
18"	13"	409-18Dpulley
24"	19"	409-24Dpulley
30"	25"	409-30Dpulley
36"	31"	409-36Dpulley
42"	37"	409-42Dpulley
48"	43"	409-48Dpulley

4" Take-up End Pulley (4" Diameter with Internal Bearings) Includes 1 3/16" Diameter Shaft

Overall Width	Face Width	Pulley with 1 3/16" Bore
12"	7"	401-12-419TUEpulley
15"	10"	401-15-419TUEpulley
18"	13"	401-18-419TUEpulley
24"	19"	401-24-419TUEpulley
30"	25"	401-30-419TUEpulley
36"	31"	401-36-419TUEpulley
42"	37"	401-42-419TUEpulley
48"	43"	401-48-419TUEpulley

401/430 Drive Snubber Roller

Overall Width	Snubber Rollers Steel
12"	401-12SRS
15"	401-15SRS
18"	401-18SRS
24"	401-24SRS
30"	401-30SRS
36"	401-36SRS
42"	401-42SRS
48"	401-48SRS

401 and 430 Return Rollers and 401 Carrier Rollers with 7/16" Hex Shaft (Return Roller Bracket ordered Separate)

Overall Width	Return Rollers Steel
12"	401-12RRS
15"	401-15RRS
18"	401-18RRS
24"	401-24RRS
30"	401-30RRS
36"	401-36RRS
42"	401-42RRS
48"	401-48RRS

430 Carrier Rollers with 7/16" Hex Shaft

Overall Width	Carrier Rollers Steel
12"	430-12CRS
15"	430-15CRS
18"	430-18CRS
24"	430-24CRS
30"	430-30CRS
36"	430-36CRS
42"	430-42CRS
48"	430-48CRS



401/430 Misc Parts

BDLR Return Carrier Bracket	401-RCA
430 Accumulator Sintered Bushing	430-SAB

460 Rollers 2 1/2" x 11 gage with 11/16 hex Axles

Overall Width	Snubber Rollers Steel
42 1/4"	460-42SRS
46 1/4"	460-46SRS
50 1/4"	460-50SRS
54 1/4"	460-54SRS
58 1/4"	460-58SRS
62 1/4"	460-62SRS
66 1/4"	460-66SRS
70 1/4"	460-70SRS
74 1/4"	460-74SRS

460 10" Drive Pulleys (10" Diameter plus Lagging) Includes 1 15/16" Diameter Shaft

Overall Width	Face Width	Pulley with 1 15/16" Bore
42 1/4"	37"	460-42Dpulley
46 1/4"	41"	460-46Dpulley
50 1/4"	45"	460-50Dpulley
54 1/4"	49"	460-54Dpulley
58 1/4"	53"	460-58Dpulley
62 1/4"	57"	460-62Dpulley
66 1/4"	61"	460-66Dpulley
70 1/4"	65"	460-70Dpulley
74 1/4"	69"	460-74Dpulley

460 6" End Pulleys Includes 1 7/16" Diameter Shaft

Overall Width	Face Width	Pulley with 1 7/16" Bore
42 1/4"	37"	460-42TUEpulley
46 1/4"	41"	460-46TUEpulley
50 1/4"	45"	460-50TUEpulley
54 1/4"	49"	460-54TUEpulley
58 1/4"	53"	460-58TUEpulley
62 1/4"	57"	460-62TUEpulley
66 1/4"	61"	460-66TUEpulley
70 1/4"	65"	460-70TUEpulley
74 1/4"	69"	460-74TUEpulley

Bearings

ID of Bearing	Part Number
1 3/16"	406-4hole19
1 7/16"	409-4hole23
1 15/16"	460-4hole31
1 7/16"	460-ETU23

Chain Guards

Drive	Part Number
406 Plastic	406-PCG
409 Plastic	409-PCG
460-Steel	460-SCG

Chain Parts:

50B12T to 50B35T	Standard Sprockets for #50 Chain
50-Chain	Feet of #50 Roller Chain
60B11T to 60B36T	Standard Sprockets for #60 Chain
60-Chain	Feet of #60 Roller Chain
80B12T to 80B30T	Standard Sprockets for #80 Chain
80-Chain	Feet of #80 Roller Chain

Touch-Up Paint

MB-SPaint	Spray Can of Metzgar Blue Touch-up Paint
MB-1gCPaint	One Gallon Can of Metzgar Blue Touch-up Paint
VG-SPaint	Spray Can of Vista Green Touch-up Paint
VG-1gCPaint	One Gallon Can of Vista Green Touch-up Paint