

**Section 3 – Belt Conveyor**

<b>Page</b>	<b>Description</b>
3-1	Belt Conveyor Index
3-2	Steps to Assembling a Complete Belt Conveyor
3-3	Elevation Examples
3-4	Power Conveyor Data Sheet
3-5	701 Belt Conveyor Specifications and Unit Model Number
3-6	801 Belt Conveyor Specifications and Unit Model Number
3-7	701 and 801 Bed Selection, Bottom Cover Pans
3-8	Belt Type and Length Selection Guide
3-9	701 and 801 Horsepower Selection
3-10	701 and 801 Motor and Reducer/Drive Model Selection
3-11	Drive Dimensional Information
3-12	End Pulley Assemblies
3-13	Gravity Wheel Feeders
3-14	Power Tail Assembly
3-15	Nose-over Bed Splice
3-16	Horizontal and Vertical Take-ups
3-17	Series 715 Belt Curve
3-18	Series 720 Brake Metering Belt
3-19	Series 725 Portable Power Helper
3-20	Series 730 Booster Stacker
3-21	Series 750 Press Conveyor
3-22	Series 760 Flat Wire Belt Conveyor
3-23	Series 765 Flat Wire Belt Conveyor
3-24	Belt Conveyor Options
3-25	Belt Conveyor Replacement Parts
3-26	Belt Conveyor Replacement Parts Continued

**Steps To Assembling a Complete Belt Conveyor Unit:**

The following steps will assist you in assembling a complete belt conveyor unit.

- 1) Determine the width of the belt you will require based on the widest product that will be conveyed on the unit.
- 2) Determine the overall length of the unit (starting point and ending point).
- 3) Determine the style of conveyor to be used.
  - 701 Slider bed conveyor is the most common and the most economical.
  - 801 Belt on Roller conveyor is used for heavy loads by reducing the amount of drive required. The rollers have less friction than the slider bed.
- 4) What is the heaviest product? How much product weight is on the conveyor total?
- 5) Select the Type of drive required.
  - End Drives are used for non-reversing applications.
  - Center Drives are required for reversing applications.
  - Nose-over End Drives are used in incline applications which are non-reversing.
- 6) Select the Motor and Reducer for the drive based on Speed and Horsepower.
- 7) Add a Nose-Over Splice if the unit is an incline and a smooth transition is required from the incline to return the product to horizontal. Multiple Nose-Overs may be utilized.
- 8) Select a Power or Gravity Feeder. These are used on Incline / Decline units. Power Feeders in the incline or decline modes provide a smooth transition between the angle and the horizontal. Power feeders are also commonly referred to as power tails.
- 9) Select End Pulleys as required.
  - One end pulley is required on an end drive conveyor without a power tail.
  - One end pulley is required on a center drive with a power tail.
  - Two end pulleys are required on a center drive without a power tail.
- 10) Select an auxiliary take-up if the length of the unit requires one, or if the end pulleys cannot be used as take-ups due to a length restriction. Belt length take-ups are required because over time the belt will stretch.
  - Center drives have a belt take-up built into the design.
  - End drives require a take-up if the end pulley cannot be adjusted due to length restrictions. The drive side is fixed so only one end pulley can be adjusted.
  - A horizontal take-up should be used on end drives with one adjustable tail pulley on conveyors 40 feet in length up to 110 feet in length.
  - A horizontal take-up should be used on end drives without an adjustable tail pulley on conveyors 10 feet in length up to 75 feet in length.
  - A vertical take-up should be used on end drives with one adjustable tail pulley on conveyors 40 feet in length up to 80 feet in length.
  - A vertical take-up should be used on end drives without an adjustable tail pulley on conveyors 10 feet in length up to 40 feet in length.
- 11) Select Accessories as required. These may include the following:
  - Guard Rail, Supports, Controls or conveyor that feeds product on the belt conveyor.



Elevation Examples of Belt Conveyor Units:

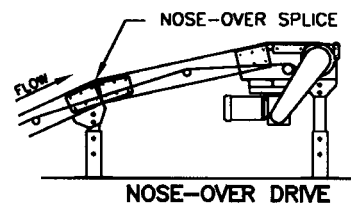
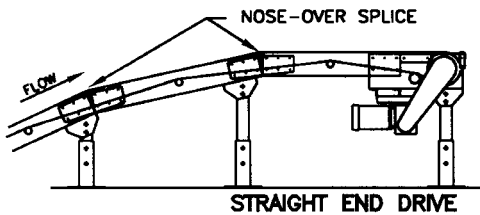
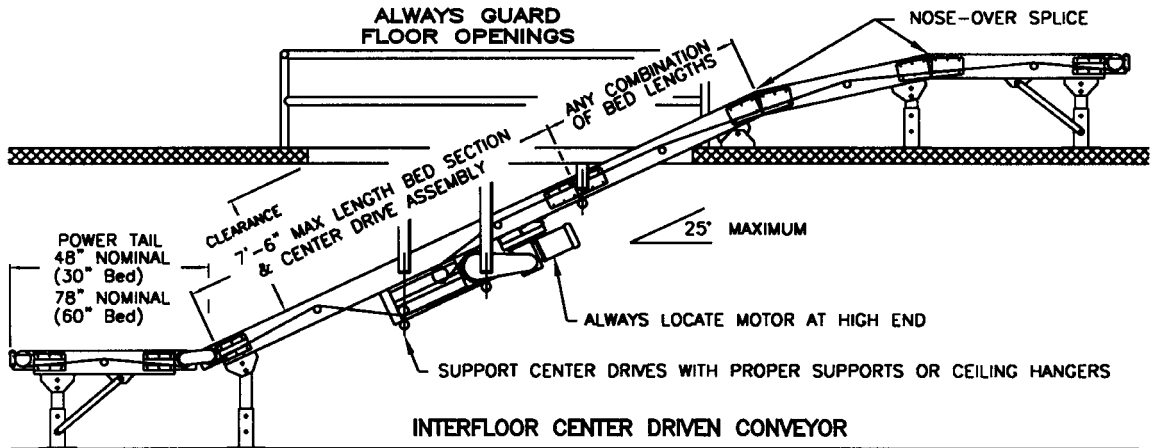
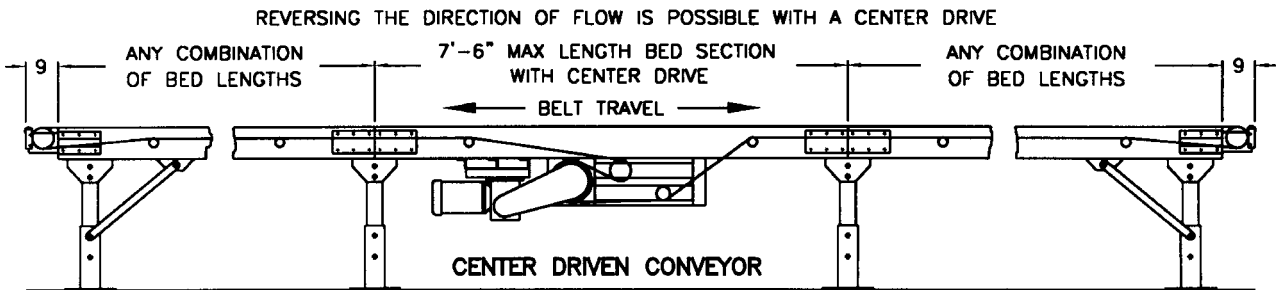
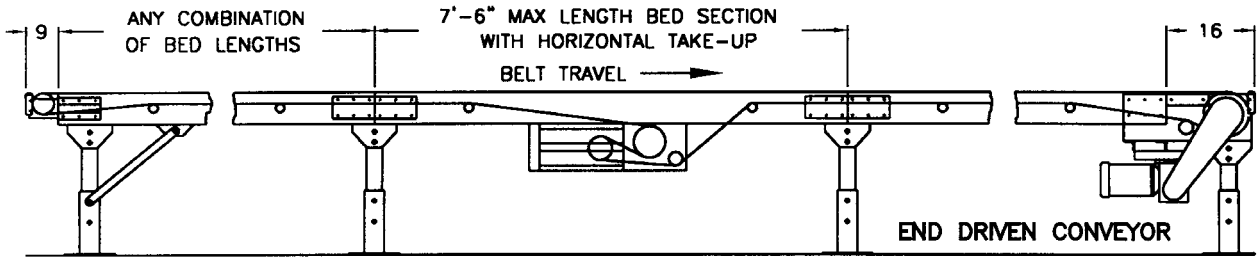



**Belt Conveyor Power Conveyor Data Sheet:**

Unit Model Number:

Overall Unit Length:

Speed of Unit:

<b>Component</b>	<b>Part Number</b>	<b>Description</b>
Drive		
Motor Horsepower		
Speed of Unit (FPM)		
Bed Construction		
Bottom Pans		
Feeders		
End Assembly		
Take-ups		
Connectors		
Belt type and length		
<b>Accessories</b>		
Guard Rails		
Trussing		
Controls		
Supports		
Finish	Metzgar Blue	



**701 Belt Conveyor Specifications and Unit Model Number:**

“A” Bed Width	“B” Belt Width
12 ½”	6
18 ½”	12
24 ½”	18
30 ½”	24
36 ½”	30
42 ½”	36
48 ½”	42

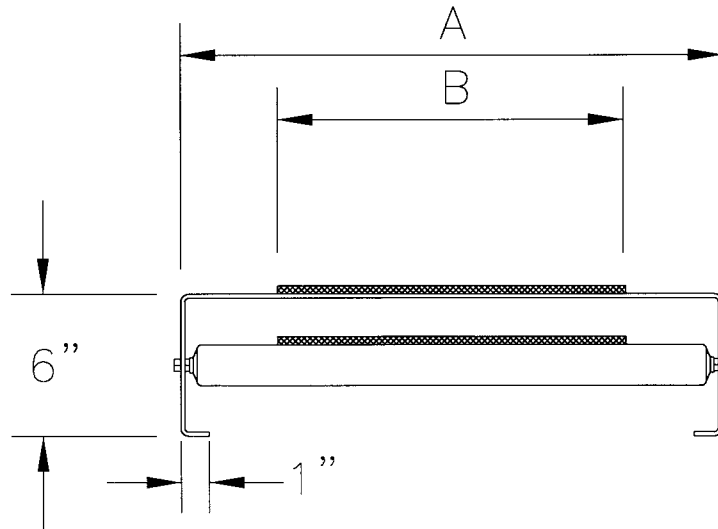

- Beds:** Box channel up to 30” wide are 12 gage galvanized x 6” deep with 1” flange. Beds 36” wide and larger are 10 gage welded and painted. All beds have bolted guardrail tube crossmembers and return rollers. A standard bed is 6 ½” wider than the belt. Allow 2 inches per side for hardware bolted to the frame.
- Drive Pulleys:** Standard Drive pulleys come in 6”, 9” or 12” diameter crowned and lagged. Drive pulley shafts come in 1 3/16” dia, 1 7/16” dia. or 1 15/16” dia.
- End Pulleys and Take-up Pulleys:** 4” diameter crowned with 1 3/16: dia. shaft. Internal mounted bearings are standard.
- Drive Snubber Roller:** Rollers are 2 ½” diameter 11 gage steel with ball bearings and 11/16” hex tube spanner and 7/16” diameter shaft.
- Belt return Idler Rollers:** Rollers are 1.9” diameter x 16 gage steel with ball bearings and 7/16” hex axles. Axles are spring loaded for easy assembly or removal.
- Belt Speed:** 60 Feet Per Minute (FPM) is the most common. Other speeds and variable speed is available as options.

**701 Belt Conveyor Model Number:**

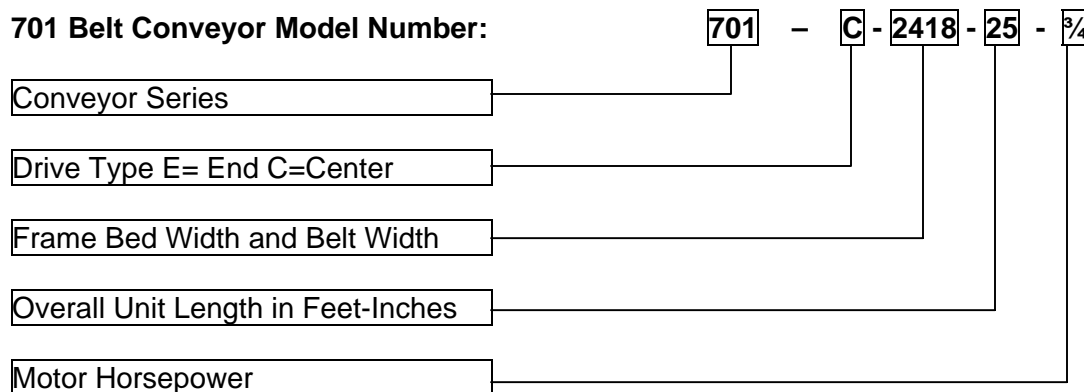



**801 Belt Conveyor Specifications and Unit Model Number:**

“A” Bed Width	“B” Belt Width	“C” Roller Width
18 1/2”	12	9 1/4”
24 1/2”	18	15 1/4”
30 1/2”	24	21 1/4”
36 1/2”	30	27 1/4”
42 1/2”	36	33 1/4”
48 1/2”	42	39 1/4”

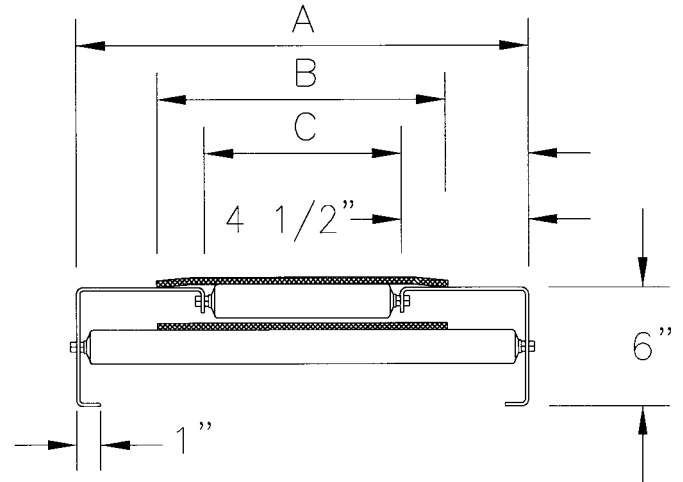

**Beds:** Box channel 12 gage galvanized x 6” deep with 1” flange.

Beds are bolted together using 11/16” hex tube and 7/16” spanner rod.

All beds have bolted guardrail tube crossmembers and return rollers.

A standard bed is 6 1/2” wider than the belt.

Allow 2 inches per side for hardware bolted to the frame.

**Carrier Rollers:** Rollers are 1.9” diameter x 16 gage steel with ball bearings and 7/16”

hex axles. Axles are spring loaded for easy assembly or removal.

The top of roller is located 1/8” above the top of conveyor bed.

Carrier rollers are available on 3”, 6”, 9” or 12” Centers.

**Drive Pulleys:** Standard Drive pulleys come in 6”, 9” or 12” diameter crowned and lagged.

Drive pulley shafts come in 1 3/16” dia, 1 7/16” dia. or 1 15/16” dia.

**End Pulleys and Take-up Pulleys:** 4” diameter crowned with 1 3/16: dia. shaft.

Internal mounted bearings are standard.

**Drive Snubber Roller:** Rollers are 2 1/2” diameter 11 gage steel with ball bearings and

11/16” hex tube spanner and 7/16” diameter shaft.

**Belt return Idler Rollers:** Rollers are 1.9” diameter x 16 gage steel with ball bearings and 7/16”

hex axles. Axles are spring loaded for easy assembly or removal.

**Belt Speed:** 60 Feet Per Minute (FPM) is the most common. Other speeds and variable

speed is available as options.

**801 Belt Conveyor Model Number:**

801 - C - 2418 - 6 - 25 - 3/4

Conveyor Series

Drive Type E= End C=Center

Frame Bed Width and Belt Width

Carrier Roller Centers 6”, 9” or 12”

Overall Unit Length in Feet-Inches

Motor Horsepower



**Belt Conveyor Bed Section Part Numbers:**

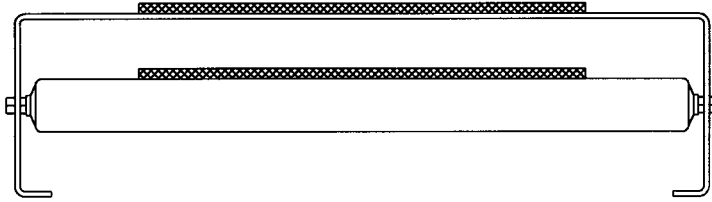

**701 Bed Section Model Number:**

**701 - 2418 - 10**

Conveyor Series

Frame Bed Width and Belt Width

Length of Bed Section

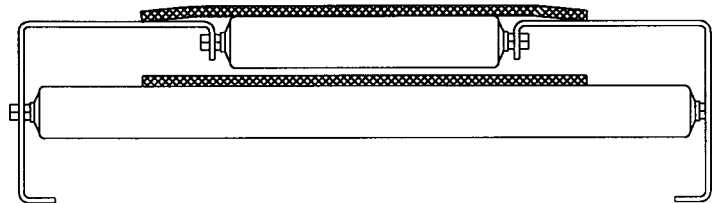

**801 Bed Section Model Number:**

**801 - 2418 - 6 - 10**

Conveyor Series

Frame Bed Width and Belt Width

Roller Centers

Length of Bed Section

**Included as standard are guard rail mounting tubes, belt return idler rollers, one pair of splice plates.**

**Standard Bed Lengths are 2'-6", 5'-0", 7'-6" and 10'-0".**

**Center Drives are assembled on 7'-6" bed sections.**

**Bottom Cover Pans:**

Bottom cover pans are used to cover the bottom side of a belt conveyor. They are used where product or personnel could come in contact with the return side of the belt. Typical applications are to cover the bottom of the unit between the floor and 7'-6" above the floor. Bottom Pans are made from 14 gage galvanized steel with mounting holes and notches for clearance for supports stand heads. The standard assembly includes mounting hardware. Specify bed width and length of bed section when ordering.

**Order Separately the Belt, Bottom Pans, Guard Rail and Supports.**



**Conveyor Belt Selection Guide:**

**Belt Type**

Description	Application	Weight of Belt Per Inch Width
120 Black PVC COS x FS	Most Horizontal / Oil and Cut Resistant	.015
120 White PVC Food Grade	Most Horizontal / Non Marking	.095
120 Black PVC Roughtop	Inclines/Declines to 15° Oil and Cut Resistant	.130
2 ply Nitrile Roughtop	Inclines/Declines to 15° Oil and Cut Resistant	.125
2 ply Rubber Roughtop	Inclines/Declines to 15° Not Oil Resistant	.130
3 ply Rubber Ridgetop	Inclines/Declines to 15° 20° Not Oil Resistant	.125
2 ply Rubber Wedgegrip	Inclines/Declines 20° to 25° Not Oil Resistant	.075

Determining the weight of the belt that will be used for the horsepower calculation.

Take the (Weight of Belt PIW x Width of the belt) x Length of the Belt in Feet = Total Weight of Belt

**Belt Length Chart**

Model	Equipment Description	Length of Belt Req'd
712	12" Straight End Drive	3'-9"
712	12" Center Drive	4'-11"
709	9" Straight End Drive	3'-2"
709	9" Nose-over End Drive	3'-8"
709	9" Center Drive	3'-6"
706	6" Straight End Drive	2'-7"
706	6" Nose-over End Drive	3'-4"
706L	6" Low Profile Center Drive	3'-1"
706L	6" Low Profile End Drive	1'-2"
701	End Pulley Assembly 419	1'-2"
701	End Pulley Assembly 523	1'-5"
701	Horizontal Take-up	2'-10"
701	Vertical Take-up	1'-4"
701	2'-6" Power Tail Assembly	7'-4"
701	5'-0" Power Tail Assembly	12'-4"
701	Main Unit Power Tail Pulley	1'-4"
NOS	Nose-over Bed Splice	0'-7"

Determining the length of the Belt for a particular unit:

- 1) Take the length of all bed sections and multiply by two.
- 2) Add the belt lengths for each assembly required (See above Chart).

**Application Notes:**

**The Temperature range on the standard belting listed above is 32° F to 150° F.**

**Consult the factory for low or high temperature applications.**

**The maximum incline for plastic totes is 15 degrees.**

**Consult the factory on applications with inclines or declines in excess of 25 degrees.**



**701 Horsepower Section:**

**To Determine the Horsepower required on a 701 Series Slider Bed Unit:**

- 1) Determine the maximum weight of product that will be on the unit at any time.
- 2) Add the weight of the belt (calculated on page 6).
- 3) Add Steps one and two together.
- 4) Use Table 1 below to determine the estimated horsepower required.

Table 1 – 701 Series Maximum Load Including Belt (Angle of Conveyor Unit)

<b>Estimated Horsepower</b>	<b>0°</b>	<b>5°</b>	<b>10°</b>	<b>15°</b>	<b>20°</b>	<b>25°</b>
1/2	595	470	400	340	300	270
3/4	905	720	610	520	460	410
<b>1</b>	1200	955	810	690	610	545
<b>1 1/2</b>	1840	1465	1240	1055	935	835
<b>2</b>	2300	1870	1615	1405	1265	1130

For Loads that are greater than listed in this table consult the factory.

**To Determine the Horsepower required on a 801 Series Belt on Roller Unit:**

- 1) Determine the maximum weight of product that will be on the unit at any time.
- 2) Multiply the Weight per Foot in Table 2 times the length of the unit.
- 3) Add Steps one and two together.
- 4) Use Table 3 below to determine the estimated horsepower required.

Table 2 – Weight of Belt and Rollers Per Linear Foot in pounds

	<b>1812</b>	<b>2418</b>	<b>3024</b>	<b>3630</b>	<b>4236</b>	<b>4842</b>
<b>6" Roller Centers</b>	10	13	16	19	22	25
<b>9" Roller Centers</b>	8	11	13	16	18	21
<b>12" Roller Centers</b>	7	10	12	14	16	18

Table 3 – 801 Series Maximum Load Including Belt (Angle of Conveyor Unit)

<b>Estimated Horsepower</b>	<b>0°</b>	<b>5°</b>	<b>10°</b>	<b>15°</b>	<b>20°</b>	<b>25°</b>
1/2	2950	1330	850	630	505	420
3/4	4525	2000	1290	955	760	640
<b>1</b>	6000	2600	1670	1240	990	830
<b>1 1/2</b>	9200	3920	2640	1820	1500	1250
<b>2</b>	13900	5900	3975	2740	2250	1875

For Loads that are greater than listed in this table consult the factory.

**Tables are based on 60 Feet Per Minute with a 1.25 service factor.**



**701 and 801 Drives:**

Horsepower / Reducer Availability 6" Drive Speed in FPM

30	40	50	60	70	80	90	100
1/2	1/2	1/2	1/2	1/2	1/2	1/2	1/2
3/4	3/4	3/4	3/4	3/4	3/4	3/4	3/4
N/A	N/A	N/A	1	1	1	1	1

Horsepower / Reducer Availability 9" Drive Speed in FPM

30	40	50	60	70	80	90	100
1/2	1/2	1/2	1/2	1/2	1/2	1/2	1/2
3/4	3/4	3/4	3/4	3/4	3/4	3/4	3/4
N/A	1	1	1	1	1	1	1
N/A	N/A	1 1/2	1 1/2	1 1/2	1 1/2	1 1/2	1 1/2
N/A	N/A	2	2	2	2	2	2

Horsepower / Reducer Availability 12" Drive Speed in FPM

30	40	50	60	70	80	90	100
N/A	1	1	1	1	1	1	1
N/A	N/A	1 1/2	1 1/2	1 1/2	1 1/2	1 1/2	1 1/2
N/A	N/A	2	2	2	2	2	2
N/A	N/A	3	3	3	3	3	3

To Determine the part number for a drive the following information is required.

- 1) Bed Width and Belt Width
- 2) If a End Drive or Center Drive is Required.
- 3) The Horsepower of the motor (From Table 1 or 3)
- 4) Determine the drive size based on the load in table 4 using the load value of step 3 of Pg 9.

Table 4 - Drive Size

Drive Size	706	709	712
701 Horizontal Unit	975	1950	2775
701 Incline Unit	404	809	1152
801 Horizontal Unit	2925	5850	8325
801 Incline Unit	559	1119	1592

**Do not exceed 120 pounds per inch of belt width working strength.**

Belt Conveyor Drive Model Number:

709 - C - 2418 - 1/2 - 60

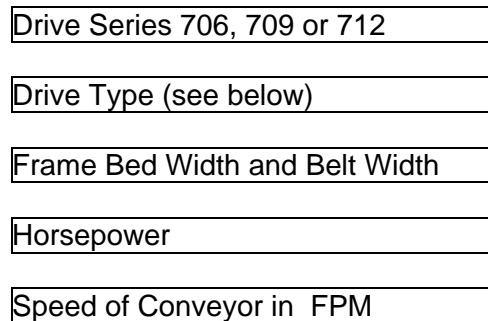

**Drive Types:**

**S=** Straight End Drive

**LPS=** Low Profile Straight End Drive

**C=** Center Drive

**LPC=** Low Profile Center Drive



**Drive Description and Dimensions:**

**Center Drive:**

Drive Pulley	"A" Dim.	"B" Dim.	"C" Dim.
12" Dia.	24	18	56
9" Dia.	16	10	30
6" Dia. LPC	13	7	28

LPC = Low Profile Center

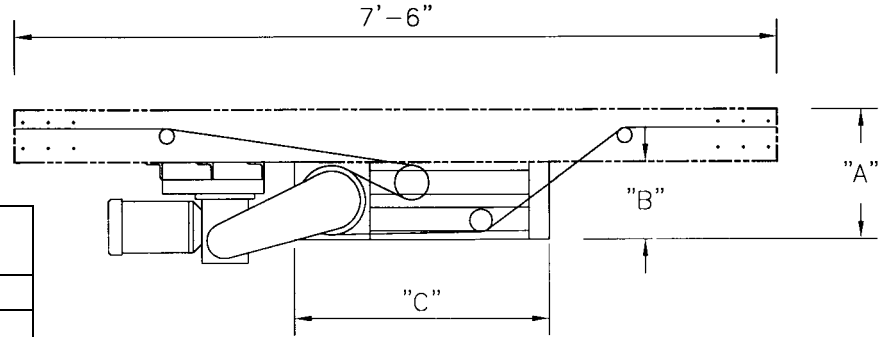

**Straight End Drive:**

Drive Pulley	"A" Dim.	"B" Dim.	"C" Dim.
12" Dia.	18 1/2	12 7/8	27
9" Dia.	16	10 1/2	24
6" Dia.	15	9 3/4	22 1/2
6" Dia. LPS	5 1/2	5 3/4	11 1/2

LPS = Low Profile Straight

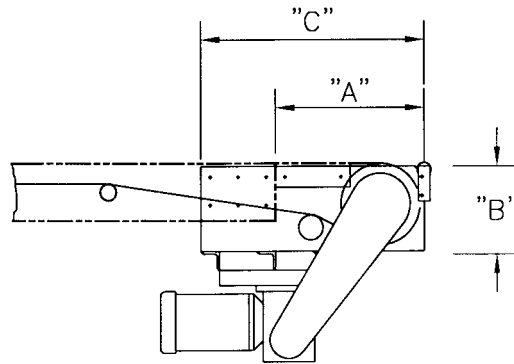

**Nose-Over End Drive:**

Drive Pulley	"A" Dim.	"B" Dim.	"C" Dim.
9" Dia.	20	10 1/2	26
6" Dia.	19	9 3/4	24 1/2

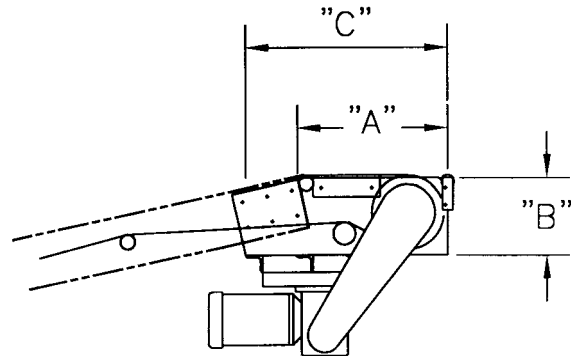



**Belt Conveyor End Pulley Assemblies:**

**419 End Assembly**

Pulley Diameter: 4 inch  
Bearings: Internal to Pulley  
Shaft Diameter: 1 3/16"

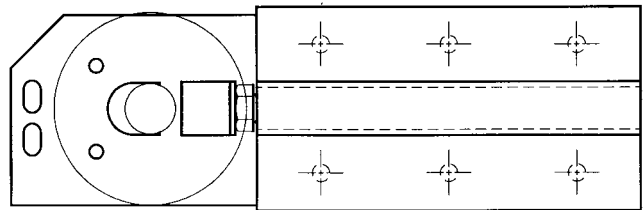
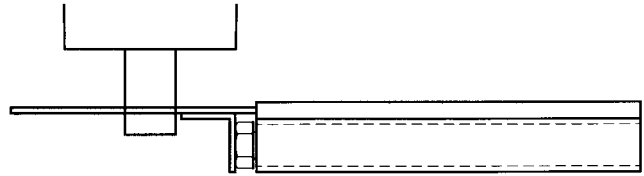

**Optional 523 End Assembly**

Pulley Diameter: 5 inch  
Bearings: Mounted outboard on slide pockets  
Shaft Diameter: 1 7/16"

One end pulley is required on an end drive conveyor without a power tail.  
One end pulley is required on a center drive with a power tail.  
Two end pulleys are required on a center drive without a power tail.

**End Pulley Model Number:**

**701EP - 2418 - 419**

Conveyor Series End Pulley

Frame Bed Width and Belt Width

End Pulley Assy (419 or 523)

**Options for 5" diameter pulley and outboard mounted bearings.**

**Standard unit Includes slide plates and pockets, pulley with internal bearings, shaft, pop-out roller, gravity connector with mounting brackets and gap plate.**



**Belt Conveyor Gravity Wheel Feeder:**

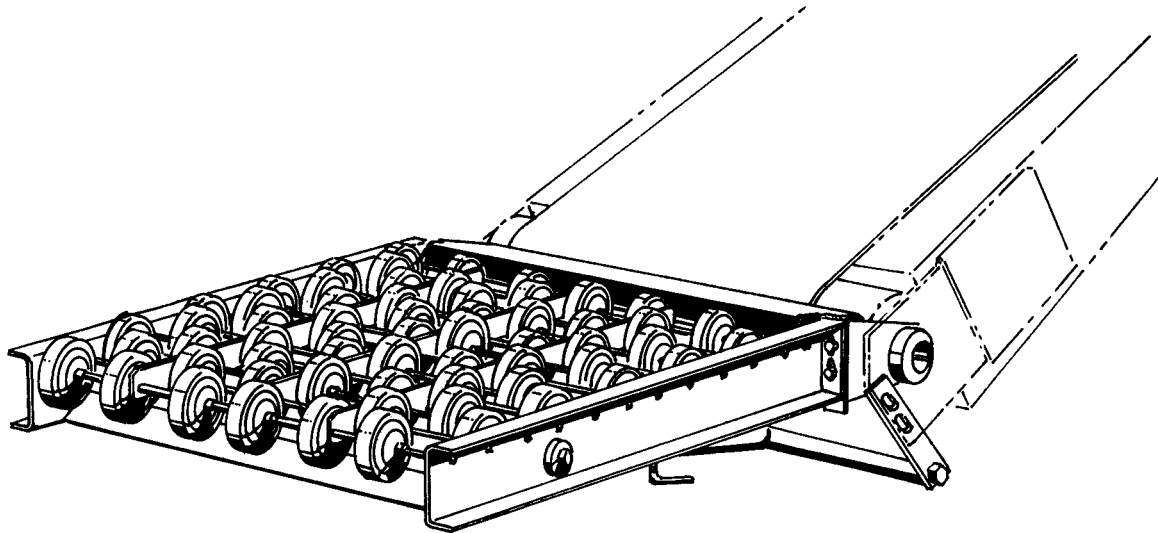

Gravity wheel feeders are normally used in a system where a gravity line is feeding onto a line booster and a power tail is not desired. Wheel feeders are also used when manually loading product on an interfloor conveyor.

Gravity wheel feeders consist of an 18" long section of wheel conveyor with close packed wheels on 1 ½" centers. The feeder attaches to the shaft of a 419 end assembly. The feeder is self-supporting with enough adjustment to allow for proper feed angle on any incline conveyor. A pivot gap plate raises the leading edge of packages declining on the unit to prevent jamming near the first row of wheels, the pivot plate bridges the gap between the beds for the inclining product.

One end pulley is required on an end drive conveyor without a power tail.

One end pulley is required on a center drive with a power tail.

Two end pulleys are required on a center drive without a power tail.

**End Pulley Model Number:**

701 - GWF - 12

Conveyor Series

Gravity Wheel Feeder

Bed Width (12,18,24 or 30)

**Standard unit includes gravity wheel section, pivoting gap plate and 419 End Assembly less the pop-out roller.**



**Belt Conveyor Power Tail Assembly:**

The power tail is a short conveyor powered through sprockets and chain, by the end pulley on the main conveyor. When feeding a incline unit, power tails transfer product smoothly onto the incline unit, eliminating the possibility of a hang-up in horizontal to incline travel. Power tails are also effective on the decline conveyor transition to horizontal.

The angle of a power tail can be adjusted to utilize any angle of incline by the main conveyor.

The 2'-6" Power Tail is available for 126, 1812 and 2418 sizes.

The 5'-0" Power Tail is available for 126, 1812, 2418, 3024, 3630, 4236, 4842 sizes.

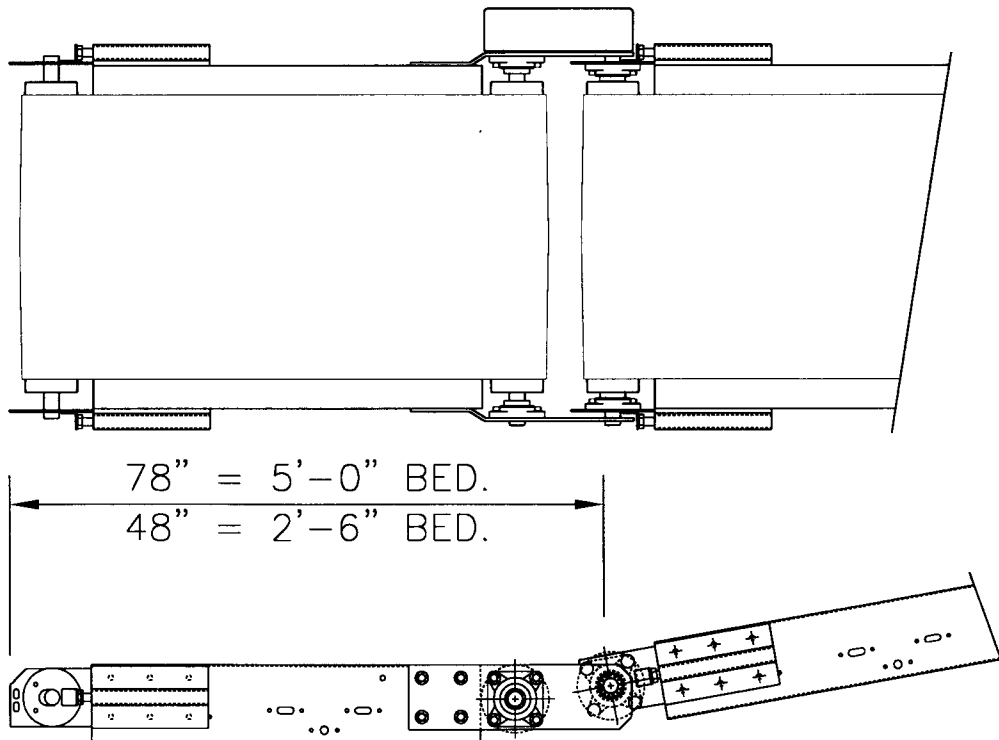

**Power Tail Model Number:**

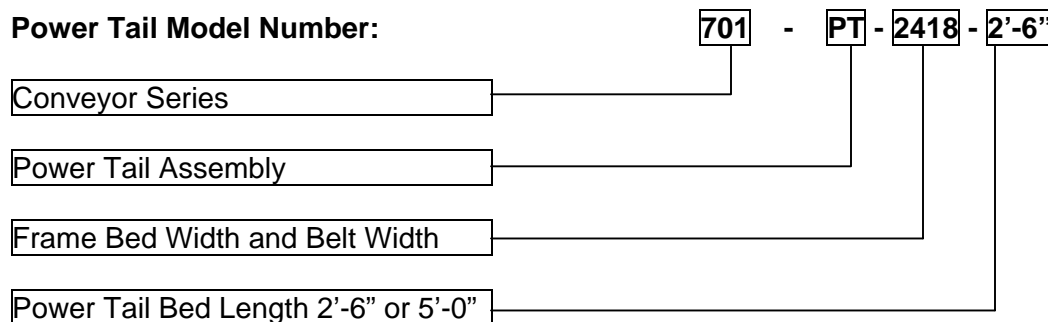

**Standard unit includes two 5" diameter pulleys with 1 3/16" shafts, one 419 end assembly with pop-out roller, gravity hook bar and PVC 120 belt squared and laced.**



**Nose over Bed Splice:**

A nose over bed splice is used to provide a smooth transition from the incline to horizontal. The angle of transition of the nose over splice can be adjusted or two can be used to smooth out a steep incline/decline angle.

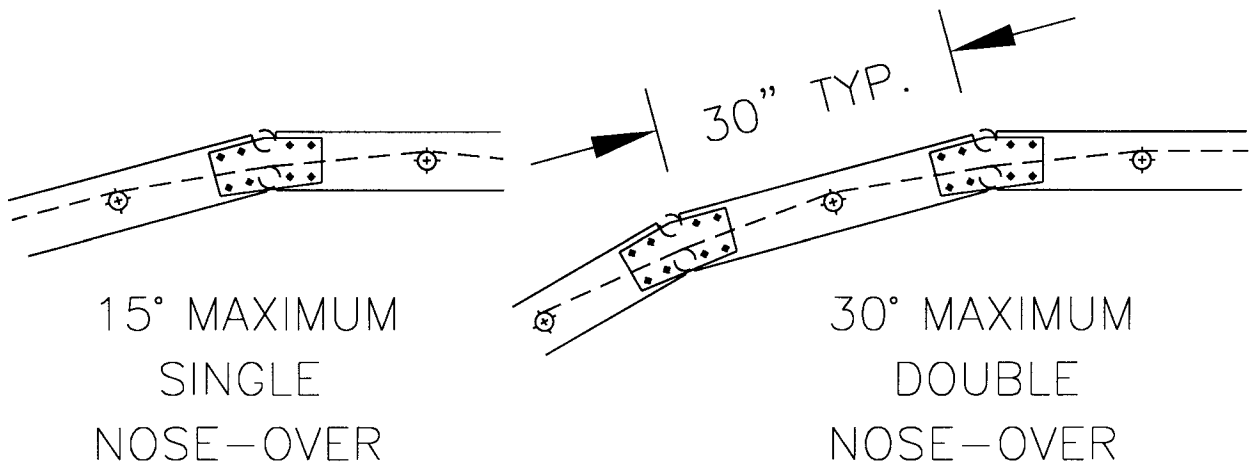

**Nose Over Model Number:**

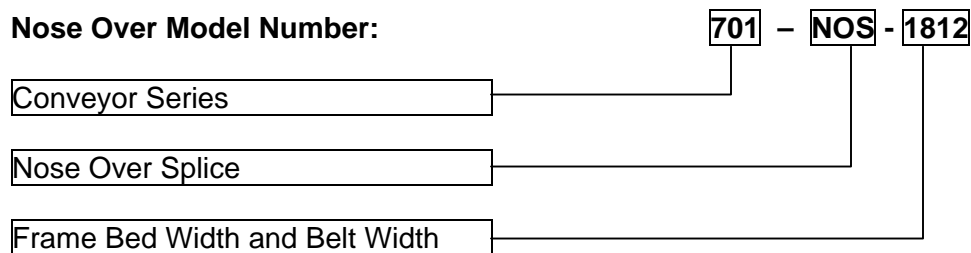

**Standard unit contains two splice plates, one snubber roller and mounting hardware.**



**Horizontal and Vertical Take-ups:**

**Horizontal Take-up:**

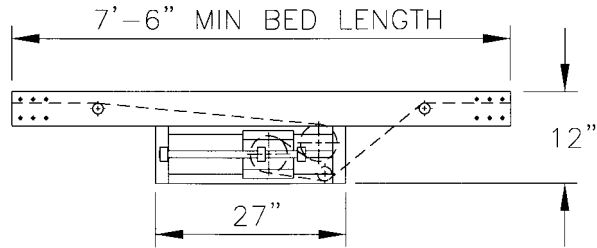

A horizontal take-up should be used on end drives with one adjustable tail pulley on conveyors 40 feet in length up to 110 feet in length.  
 A horizontal take-up should be used on end drives without an adjustable tail pulley on conveyors 10 feet in length up to 75 feet in length.

**Horizontal Take-up Model Number:**

**701 - HTU - 1812**

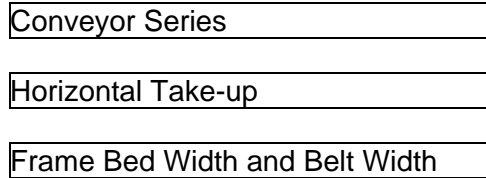

**Standard unit includes a take-up frame assembly with snubber roller, two 4" diameter pulleys with 1 3/16" diameter shafts and guards.**

**Vertical Take-up:**

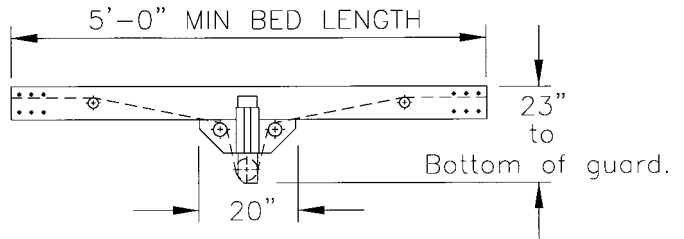

A vertical take-up should be used on end drives with one adjustable tail pulley on conveyors 40 feet in length up to 80 feet in length.  
 A vertical take-up should be used on end drives without an adjustable tail pulley on conveyors 10 feet in length up to 40 feet in length.

**Vertical Take-up Model Number:**

**701 - VTU - 1812**

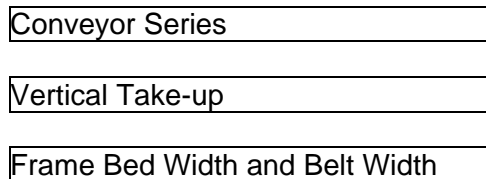

**Standard unit includes a take-up frame assembly with two snubber rollers, one 4" diameter pulley with 1 3/16" diameter shafts and guards.**



**Series 715 Powered Belt Curve Specifications:**

Belt Conveyor Section – v10.01

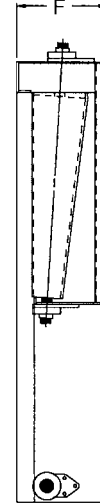
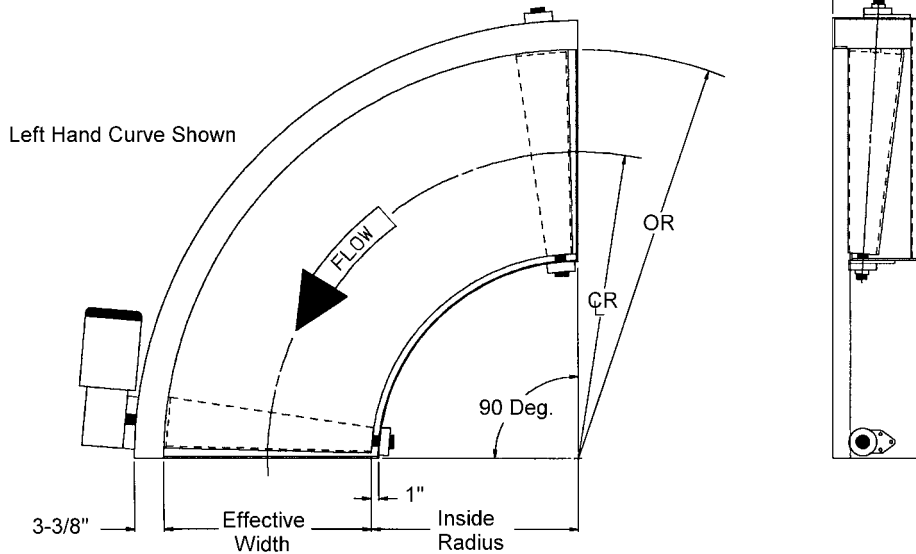

Outside Radius "OR"	Effective Belt Width	Inside Radius of Belt	Center Line Radius "CR"	Frame Channel "F"	Pulley Shaft Diameter	Maximum Live Load On Curve	
36"	6"	30"	33"	10 7/8"	1"	400 lbs	
	8"	28"	32"				
	12"	24"	30"				
48"	12"	36"	42"				
	18"	30"	39"				
	20"	28"	38"				
60"	24"	24"	36"	12 1/4"	1 3/16"	600 lbs	
	24"	36"	48"				
	30"	30"	45"				
72"	36"	24"	42"	13 7/8"	1 7/16"	700 lbs	
	36"	36"	54"				
	42"	30"	51"				
87"	48"	24"	48"	12 3/4"		1 7/16"	800 lbs
	36"	51"	69"				
	42"	45"	66"				
	48"	39"	63"				

**715 Series Specifications:**

- Belt: Black PVC other belts are available as options.
- Side Frame: 10 gage
- Standard Drive pulley is tapered with rough top lagging.
- Motor: 230/460 volt, 3 phase, 60 Hz specify voltage when ordering.
- Belt Speed: 60 Feet Per Minute (FPM) at the centerline of the carrying surface
- Other speeds are available as options.

**715 Unit Model Number:**

**715BC - 6024 - 90 - RH**

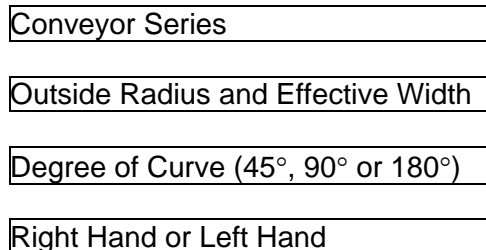

**Order Controls and supports separately.**



**Series 720 Brake Metering Belt Specifications:**

The series 720 brake metering belt is a short horizontal belt conveyor used to singulate, meter, retard or speed up product flow in a system.

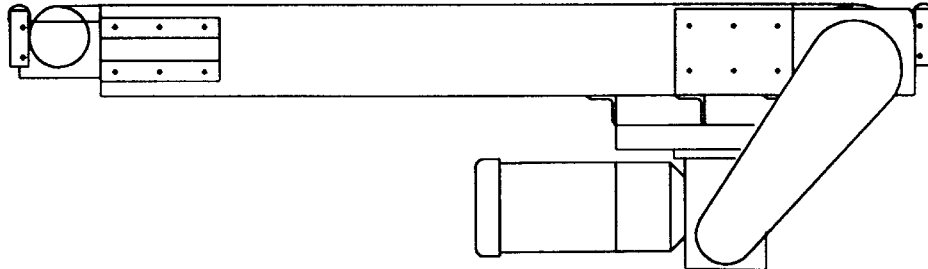

Belt: PVC Roughtop

Beds: Box channel up to 30" wide are 12 gage galvanized x 6" deep with 1" flange.

Beds 36" wide and larger are 10 gage welded and painted. All beds have bolted guardrail tube crossmembers and return rollers. A standard bed is 6 1/2" wider than the belt. Allow 2 inches per side for hardware bolted to the frame.

Drive Pulley: Standard Drive pulley is 6" diameter crowned and lagged.

Drive pulley shaft is 1 3/16" dia.

Motor: 1/2 Hp 230/460 volt, 3 phase, 60 Hz specify voltage when ordering.

Clutch/Brake: Included on standard unit with 120vac rectifier. Form "C" relay contacts are required to operate the clutch/brake.

End Pulleys: 4" diameter crowned with 1 3/16" dia. shaft. Internal mounted bearings are standard.

Drive Snubber Roller: Rollers are 2 1/2" diameter 11 gage steel with ball bearings and 11/16" hex tube spanner and 7/16" diameter shaft.

Belt return Idler Rollers: Rollers are 1.9" diameter x 16 gage steel with ball bearings and 7/16" hex axles. Axles are spring loaded for easy assembly or removal.

Belt Speed: 60 Feet Per Minute (FPM) is the most common. Other speeds are available as options.

**720 Unit Model Number:**

**720-BB - 1812 - 2'-6" - 1/2**

Conveyor Series

Frame Bed Width and Belt Width

Length of Bed

Horsepower

The standard unit is 3'-8" overall length. The bed length can be increased in one foot increments to a maximum of 8'-8" overall length.

Order Controls and supports separately.



**Series 725 Portable Power Helper Specifications:**

The series 725 Power Helper is a versatile unit that is easily moved to a stairway, loading dock or assembly operation. A convenient lift handle allows one person to maneuver into position.

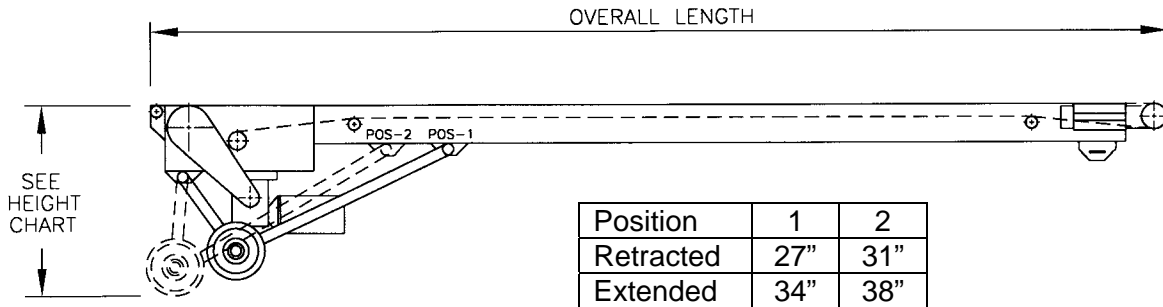

Belt: Rubber Ridge Top

Beds: Box channel 1/8" Aluminum x 6" deep with 1" flange.

Standard Widths are 1812 and 2418.

Drive Pulley: Standard Drive pulley is 9" diameter crowned and lagged.

Drive pulley shafts is 1 7/16" dia.

Motor: 3/4 Hp 115, 1 phase, 60 Hz

End Pulley: 4" diameter crowned with 1 3/16" dia. shaft. Internal mounted bearings are standard.

Drive Snubber Roller: Rollers are 2 1/2" diameter 11 gage steel with ball bearings and 11/16" hex tube spanner and 7/16" diameter shaft.

Belt return Idler Rollers: Rollers are 1.9" diameter x 16 gage steel with ball bearings and 7/16" hex axles. Axles are spring loaded for easy assembly or removal.

Belt Speed: 60 Feet Per Minute (FPM) is Standard. Other speeds and variable speed is available as options.

Supports: Adjustable undercarriage at drive end with 8" diameter wheels. Overall width of the support is 24 inches wider than the bed width.

Controls: Reversing Controls Mounted and Wired to The Motor.

**725 Unit Model Number:**

**725-PPH - 1812 - 10' - 3/4**

Conveyor Series

Frame Bed Width and Belt Width

Overall Length of Unit

Horsepower

**The standard units are 10', 12', 15', 17', and 22' long overall length.**

**The Maximum Distributed load for a horizontal application is 625 pounds.**

**The Maximum Distributed load for a 30° incline is 235 pounds.**



**Series 730 Booster Stacker Specifications:**

The series 730 Booster Stacker is a versatile unit which is used for conveying product in processing operations to make light work of raising and lowering material to or from storage.

Unit Length	Max Elevation at 30° Incline	Base Length
11'-3"	8'-3"	7'-0"
13'-9"	9'-6"	7'-0"
16'-3"	10'-9"	9'-0"

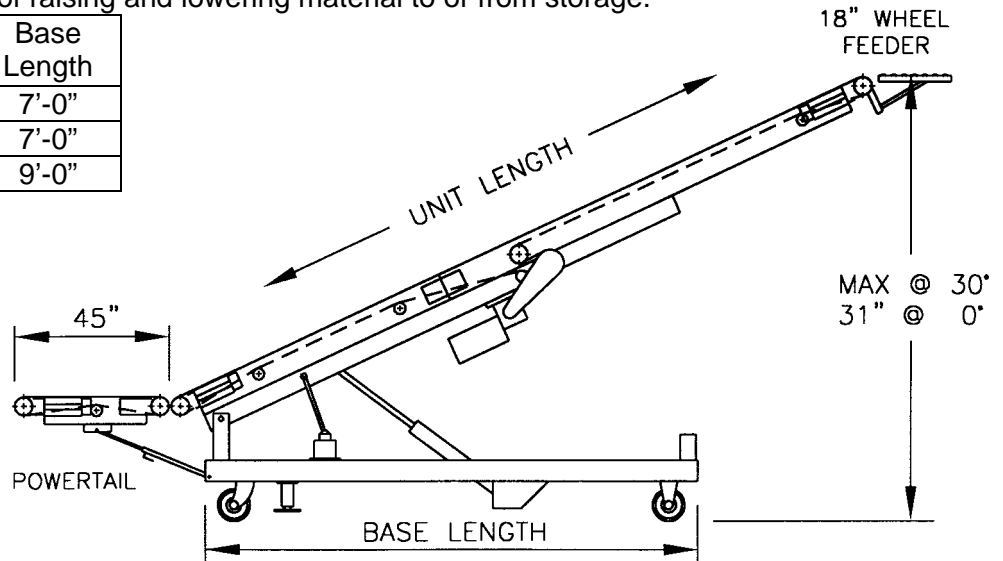

Belt: Rubber Ridge Top

Beds: Box channel 12 gage galvanized x 6" deep with 1" flange.  
Standard Widths are 1812 and 2418.

Drive Pulley: Standard Drive pulley is 6" diameter crowned and lagged.  
Drive pulley shafts is 1 3/16" dia.

Motor: 3/4 Hp 115, 1 phase, 60 Hz

End Pulleys: 4" diameter crowned with 1 3/16" dia. shaft. Internal mounted bearings are standard.

Drive Snubber Roller: Rollers are 2 1/2" diameter 11 gage steel with ball bearings and 11/16" hex tube spanner and 7/16" diameter shaft.

Belt return Idler Rollers: Rollers are 1.9" diameter x 16 gage steel with ball bearings and 7/16" hex axles. Axles are spring loaded for easy assembly or removal.

Belt Speed: 60 Feet Per Minute (FPM) is Standard.

Portable Base: 10 gage x 4 1/2" x 1 1/4" flange fabricated channel with 8" diameter casters.

Two casters are fixed and two are swivel type. Overall Width is Frame Width plus 12".

Two floor locks are used to hold the unit in position.

Hydraulic Jack: 2" dia. bore x 18" stroke hydraulic ram with hand operated pump and reservoir.

Controls: Reversing Controls Mounted and Wired to The Motor.

**730 Unit Model Number:**

**730-BS - 1812 - 11' - 3/4**

Conveyor Series

Frame Bed Width and Belt Width

Length of Bed

Horsepower

**The standard units are 11', 14', and 16' long overall length.**

**The Maximum Distributed load for a horizontal application is 625 pounds.**

**The Maximum Distributed load for a 30° incline is 235 pounds.**

**Optional Equipment: power feeders and/or gravity wheel feeders.**



**Series 750 Press Conveyor Specifications:**

The series 750 Press Conveyor is designed to carry punch press formed or cast parts from a machine into a bin.

Overall Length	7'-0"	9'-6"	12'-0"
Maximum	4'-10 1/2"	6'-8"	8'-5 1/2"
Minimum	4'-4 1/2"	5'-4"	7'-8"
Horizontal Projection	5'-7"	7'-4"	9'-2"

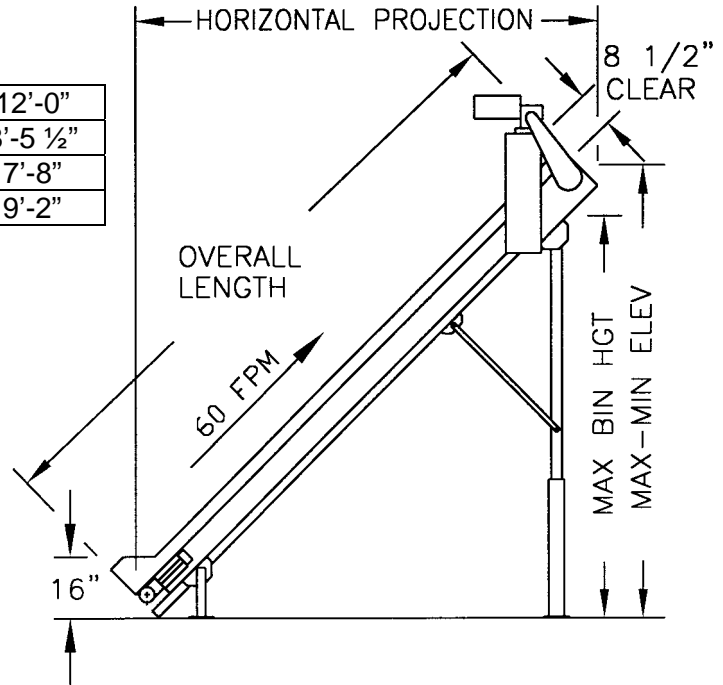

Belt: PVC 120 with 1 1/2" cleats on 12" centers.

Beds: Box channel 12 gage galvanized x 6" deep with 1" flange.

Standard Widths are 126, 1812 and 2418. Belt Return pans are mounted on 9'-6" and 12' overall length units.

Guardrail: 3" high angle guardrail and flipper gate located on the low end.

Drive Pulley: Standard Drive pulley is 6" diameter crowned and lagged.

Drive pulley shaft is 1 3/16" dia.

Motor: 1/2 Hp 115, 1 phase, 60 Hz

End Pulleys: 4" diameter crowned with 1 3/16" dia. shaft. Internal mounted bearings are standard.

Belt Speed: 60 Feet Per Minute (FPM) is Standard. Other Speeds are Available.

Supports: C700 series Adjustable "H" style Supports

Controls: Non-Reversing Manual Motor Starter Mounted and Wired to the Motor.

**750 Unit Model Number:**

**750-PC - 1812 - 7' - 1/2**

Conveyor Series

Frame Bed Width and Belt Width

Length of Bed

Horsepower

***This unit is not recommended for thin parts such as washers.***

**Optional Equipment Casters for the high end support, other voltages, widths or number of cleats.**



**Series 760 Flat Wire Belt on Slider Bed Conveyor Specifications:**

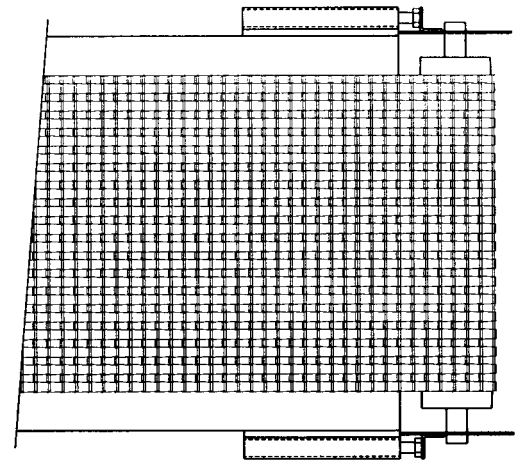
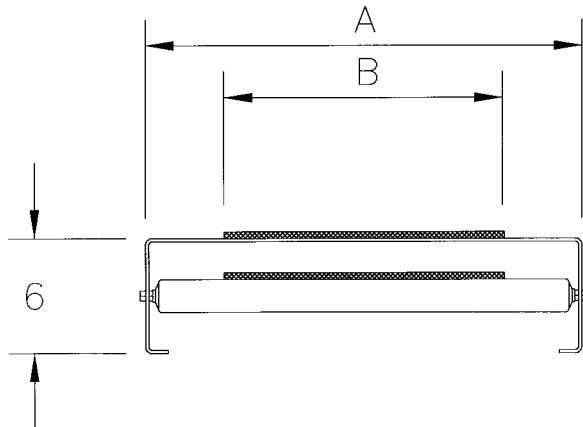

Bed "A"	Belt "B"
18 1/2"	12"
24 1/2"	18"
30 1/2"	24"

Belt: 1/2" x 1" "Flat Wire" galvanized with safety cinched edge. Picket 3/8" x 0.046" Flat Wire with 12 gage connectors.

Beds: Box channel 12 gage galvanized x 6" deep with 1" flange.

Standard Widths are 1812, 2418 and 3024

Drive Pulley: Number 6 sprockets on 6" centers. Drive shaft is 1 3/16" dia. keyed with setscrews.

Motor: 3/4 Hp 230/460, 3 phase, 60 Hz

End Pulleys: 4" diameter flat faced with 1 3/16" dia. shaft. Internal mounted bearings are standard.

Belt return Idler Rollers: Rollers are 1.9" diameter x 16 gage steel with ball bearings and 7/16" hex axles. Axles are spring loaded for easy assembly or removal.

Belt Speed: 60 Feet Per Minute (FPM) is Standard. Other Speeds are Available.

**760 Unit Model Number:**

**760-FW - 1812 - 7' - 3/4**

Conveyor Series

Frame Bed Width and Belt Width

Length of Bed

Horsepower



Series 765 Flat Wire Belt on Roller Bed Conveyor Specifications:

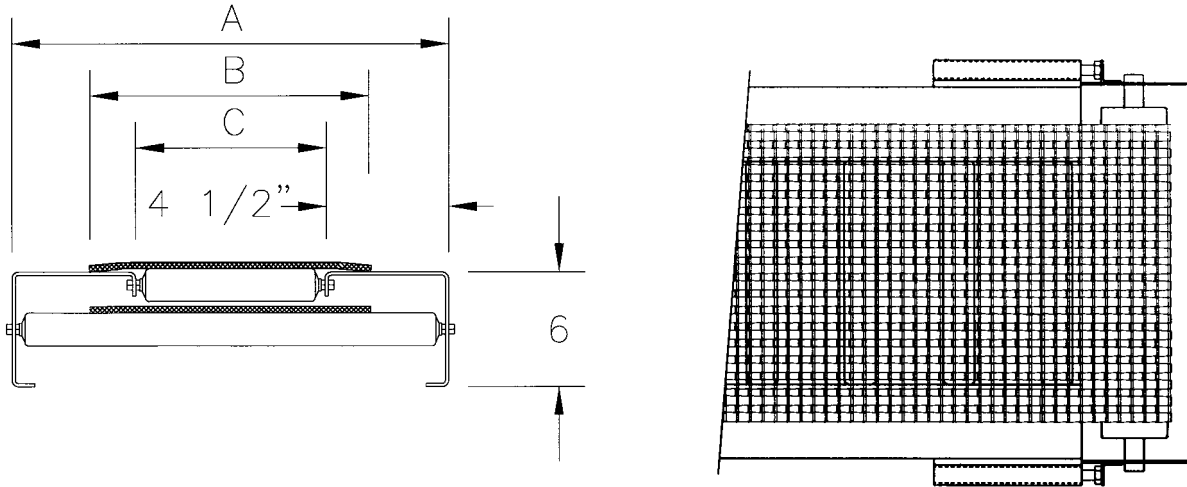

Bed "A"	Belt "B"	Roller "C"
18 1/2"	12"	9 1/4"
24 1/2"	18"	15 1/4"
30 1/2"	24"	21 1/4"

Belt: 1/2" x 1" "Flat Wire" galvanized with safety cinched edge. Picket 3/8" x 0.046" Flat Wire with 12 gage connectors.

Beds: Box channel 12 gage galvanized x 6" deep with 1" flange. Bolted together with 11/16" hex tube and 7/16" spanner rod. Standard Widths are 1812, 2418 and 3024

Belt Carrier Rollers: Rollers are 1.9" diameter x 16 gage steel with ball bearings and 7/16" hex axles on 6" centers. Axles are spring loaded for easy assembly or removal.

Drive Pulley: Number 6 sprockets on 6" centers. Drive shaft is 1 3/16" dia. keyed with setscrews.

Motor: 3/4 Hp 230/460, 3 phase, 60 Hz

End Pulleys: 4" diameter flat faced with 1 3/16" dia. shaft. Internal mounted bearings are standard.

Belt return Idler Rollers: Rollers are 1.9" diameter x 16 gage steel with ball bearings and 7/16" hex axles. Axles are spring loaded for easy assembly or removal.

Belt Speed: 60 Feet Per Minute (FPM) is Standard. Other Speeds are Available.

765 Unit Model Number:

765-FW - 1812 - 7' - 3/4

Conveyor Series

Frame Bed Width and Belt Width

Length of Bed

Horsepower



**Belt Conveyor Options:**

**Options include widths, lengths and controls  
Consult factory with a dimensional sketch of the desired unit.**

**Frame Options:**

Special Widths to match an Existing Conveyor  
Special Paint Colors  
Powder Coated Frames  
Bright Zinc Plating on Frames

**801 Belt on Roller Options:**

Special Roller Widths  
Upgrade Roller Bearings  
Bright Zinc Plating on Rollers  
Pinned Roller Axles

**Drive Options:**

Single or Three Phase Motors  
Clutch/Brake Assemblies  
Timing Belt Components  
Brake Motors



**Belt Conveyor Replacement Parts:**

**6" Drive Pulleys (5" Diameter plus Lagging) Includes 1 3/16" Diameter Shaft**

Overall Width	Belt Width	Face Width	Pulley with 1 3/16" Bore
12 1/2"	6"	7"	<b>706-126Dpulley</b>
18 1/2"	12"	13"	<b>706-1812Dpulley</b>
24 1/2"	18"	19"	<b>706-2418Dpulley</b>
30 1/2"	24"	25"	<b>706-3024Dpulley</b>
* 36 1/2"	30"	31"	<b>706-3630Dpulley</b>
* 42 1/2"	36"	37"	<b>706-4236Dpulley</b>
* 48 1/2"	42"	43"	<b>706-4842Dpulley</b>

\* = For power tail drive pulleys only

**9" Drive Pulleys (8" Diameter plus Lagging) Includes 1 7/16" Diameter Shaft**

Overall Width	Belt Width	Face Width	Pulley with 1 7/16" Bore
12 1/2"	6"	7"	<b>709-126Dpulley</b>
18 1/2"	12"	13"	<b>709-1812Dpulley</b>
24 1/2"	18"	19"	<b>709-2418Dpulley</b>
30 1/2"	24"	25"	<b>709-3024Dpulley</b>
36 1/2"	30"	31"	<b>709-3630Dpulley</b>
42 1/2"	36"	37"	<b>709-4236Dpulley</b>
48 1/2"	42"	43"	<b>709-4842Dpulley</b>

**12" Drive Pulleys (12" Diameter plus Lagging) Includes 1 15/16" Diameter Shaft**

Overall Width	Belt Width	Face Width	Pulley with 1 15/16" Bore
18 1/2"	12"	13"	<b>712-1812Dpulley</b>
24 1/2"	18"	19"	<b>712-2418Dpulley</b>
30 1/2"	24"	25"	<b>712-3024Dpulley</b>
36 1/2"	30"	31"	<b>712-3630Dpulley</b>
42 1/2"	36"	37"	<b>712-4236Dpulley</b>
48 1/2"	42"	43"	<b>712-4842Dpulley</b>

**4" End Pulley (4" Diameter with Internal Bearings) Includes 1 3/16" Diameter Shaft**

Overall Width	Belt Width	Face Width	Pulley with 1 3/16" Bore
12 1/2"	6"	10"	<b>701-126-419Epulley</b>
18 1/2"	12"	16"	<b>701-1812-419Epulley</b>
24 1/2"	18"	22"	<b>701-2418-419Epulley</b>
30 1/2"	24"	28"	<b>701-3024-419Epulley</b>
36 1/2"	30"	34"	<b>701-3630-419Epulley</b>
42 1/2"	36"	40"	<b>701-4236-419Epulley</b>
48 1/2"	42"	46"	<b>701-4842-419Epulley</b>

**5" End Pulley (5" Diameter with Internal Bearings) Includes 1 7/16" Diameter Shaft**

Overall Width	Belt Width	Face Width	Pulley with 1 7/16" Bore
12 1/2"	6"	10"	<b>701-126-523Epulley</b>
18 1/2"	12"	16"	<b>701-1812-523Epulley</b>
24 1/2"	18"	22"	<b>701-2418-523Epulley</b>
30 1/2"	24"	28"	<b>701-3024-523Epulley</b>
36 1/2"	30"	34"	<b>701-3630-523Epulley</b>
42 1/2"	36"	40"	<b>701-4236-523Epulley</b>
48 1/2"	42"	46"	<b>701-4842-523Epulley</b>

**701/801 Snubber Roller – 2-1/2" Diameter 11ga. w/ 11/16" Hollow Hex Axle**

Overall Width	Belt Width	Snubber Rollers Steel
12 1/2"	6"	<b>701-126SRS</b>
18 1/2"	12"	<b>701-1812SRS</b>
24 1/2"	18"	<b>701-2418SRS</b>
30 1/2"	24"	<b>701-3024SRS</b>
36 1/2"	30"	<b>701-3630SRS</b>
42 1/2"	36"	<b>701-4236SRS</b>
48 1/2"	42"	<b>701-4842SRS</b>



**701/801 Return Rollers - 1.9" Diameter 16ga. with 7/16" Hex Shaft**

Overall Width	Belt Width	Return Rollers Steel
12 ½"	6"	<b>701-126RRS</b>
18 ½"	12"	<b>701-1812RRS</b>
24 ½"	18"	<b>701-2418RRS</b>
30 ½"	24"	<b>701-3024RRS</b>
36 ½"	30"	<b>701-3630RRS</b>
42 ½"	36"	<b>701-4236RRS</b>
48 ½"	42"	<b>701-4842RRS</b>

**801 Carrier Rollers – 1.9" Diameter 16ga. with 7/16" Hex Shaft**

Overall Width	Belt Width	Carrier Rollers Steel
12 ½"	6"	<b>801-126CRS</b>
18 ½"	12"	<b>801-1812CRS</b>
24 ½"	18"	<b>801-2418CRS</b>
30 ½"	24"	<b>801-3024CRS</b>
36 ½"	30"	<b>801-3630CRS</b>
42 ½"	36"	<b>801-4236CRS</b>
48 ½"	42"	<b>801-4842CRS</b>

**Four Hole Flange Bearings**

ID of Bearing	Part Number
1 3/16"	<b>706-4hole19</b>
1 7/16"	<b>709-4hole23</b>
1 15/16"	<b>712-4hole31</b>

**Plastic Chain Guards**

Drive	Part Number
706	<b>706-PCG</b>
709 & 712	<b>709-PCG</b>
Power Tail	<b>701-PT-PCG</b>

**Chain Parts:**

<b>50B12T to 50B35T</b>	Standard Sprockets for #50 Chain
<b>50-Chain</b>	Feet of #50 Roller Chain
<b>60B11T to 60B36T</b>	Standard Sprockets for #60 Chain
<b>60-Chain</b>	Feet of #60 Roller Chain
<b>80B12T to 80B30T</b>	Standard Sprockets for #80 Chain
<b>80-Chain</b>	Feet of #80 Roller Chain

**Touch-Up Paint**

<b>MB-SPaint</b>	Spray Can of Metzgar Blue Touch-up Paint
<b>MB-1gCPaint</b>	One Gallon Can of Metzgar Blue Touch-up Paint
<b>VG-SPaint</b>	Spray Can of Vista Green Touch-up Paint
<b>VG-1gCPaint</b>	One Gallon Can of Vista Green Touch-up Paint

**Notes:**